

## SPECIFICATION / 規格表

Product Name / 產品名稱	Raptor E550 3-Blade
Item No. / 料號	4732-A23
Rotor Head / 主旋翼頭型式	3-Blade
Length / 總長	1,150 mm (45.27")
Width / 總寬	140 mm (5.51")
Height / 總高	346 mm (13.62")
Full Weight w/o Batt. / 全配重量不含電池	5.64lb (2,558g)
Main Rotor Diameter / 主旋翼旋轉直徑	1,245 mm (45")
Tail Rotor Diameter / 尾旋翼旋轉直徑	237 mm (9.33")
Gear Ratio / 齒輪傳動比	1:10.09:4.56
Main Rotor Length / 主旋翼長度	550 mm (23.62")
Tail Rotor Length / 尾旋翼長度	95 mm (3.74")
Applied Battery Pack / 電池	Lipo 6S, 3.7-5.0Ah

## FEATURES / 特色

1. 95% assembled and pre-adjusted at the factory
2. High-precise 140-degree ECOPM control system
3. 1150KV motor & 80A build-in BEC ESC for 6S power configuration
4. DS0606n digital tail servo
5. High-torque, metal gear cyclic servos
6. GT5.2 · 3AXIS gyro, suitable for 760/1520  $\mu$ s digital tail servo
7. Lightweight tail boom support bracket
8. Easy to install tail rod guides
9. Reinforced support bracket
10. Metal tail boom clamp
11. 2-piece assembled carbon frames
12. Lower and modern skid
13. High-performance 550 mm carbon main blades
14. Larger room for a 5.0Ah 6S lipo battery pack
15. New ABS canopy and decoration

1. 原廠組裝及設定完成
2. 高可靠度140度十字盤控制系統
3. 6-cell 鋰聚電池動力配置
4. DS0606n窄頻數位尾舵機
5. 高扭力，金屬齒輪面舵機
6. GT5.2三軸陀螺儀，兼容760/1520  $\mu$ s數位伺服機
7. 輕量化尾管支撐桿座
8. 快拆式尾舵拉桿導環
9. 強化支撐桿架
10. 金屬尾管固定夾座
11. 兼且耐用度及方便維修的塑膠側板組
12. 低重心新型腳架組
13. 高品質550 mm碳纖維槳
14. 加大電池空間，可適用5.0Ah 6S鋰電池
15. 新設計ABS機殼及彩貼



# RAPTOR E550 3-BLADE INSTRUCTION MANUAL

Electric . 3-Blade Edition 使用說明書



No. 4732-A23



This radio control model is not a toy! Before beginning assembly, please read this manual thoroughly.

本產品為高性能模型非一般玩具，組裝與操作前請詳閱本產品說明書。

The contents are subject to change without prior notice due to product improvements and specification changes.

本套件所附之零件可能跟圖示有所差異。因產品後續之設計研發或功能不斷改善之原因，我們將保留產品規格變更權利，不再另行通知使用者。



# RAPTOR E550 3-BLADE

Electric . 3-Blade Edition

## CONTENTS

<b>INTRO &amp; CAUTION</b> 簡介與注意事項	2
<b>CONTENTS INCLUDED</b> 內容物說明	4
<b>ADDITIONAL ITEMS REQUIRED</b> 另購配件	4
<b>TOOLS REQUIRED FOR MAINTENANCE</b> 另購維修工具	4
<b>SET-UP SECTION</b> 設定程序說明	
ASSEMBLY 組裝說明	5
DEVICE CONNECTION 設備連接說明	5
GT5.2 GYRO SETTING 三軸陀螺儀	6
MODEL & SWASHPLATE SETTING 模型及十字盤模式設定	8
SWASHPLATE & SERVO MOVEMENT SETTING 十字盤及伺服機動作設定	8
LINKAGES AND SERVO NEUTRAL ADJUSTMENT 連桿及伺服機中立點調整	9
COLLECTIVE PITCH RANGE SETTING 螺距範圍設定	10
TAIL AND GYRO SETTING 尾舵及陀螺儀設定	10
ESC SETTING 電子調速器設定	11
CURVE SETTING 曲線設定	12
BLADE TRACKING ADJUSTMENT 主旋翼軌跡調整	13
<b>CAUTIONS OF Li-Po BATTERY PACK USING</b> 鋰聚電池使用注意事項	14
<b>AFTER FLIGHT CHECKLIST</b> 飛行後的檢查項目	14
<b>REGULAR MAINTENANCE</b> 定期保養事項	14
<b>EXPLODED VIEW &amp; SPARE PARTS LIST</b> 爆炸圖檢索 & 維修零件包表格	
MAIN ROTOR HEAD 主旋翼頭	15
MAIN FRAME(LANDING SKID) 本體(腳架)	17
MAIN GEAR & ROTOR HEAD LINKAGE ROD 主齒輪與主旋翼頭連桿	19
TAIL ROTOR & TAIL UNIT 尾旋翼與尾部總成	21
SERVO WITH LINKAGE ROD 伺服機連桿	23
MAIN ROTOR BLADE & CANOPY & TAIL BOOM 主旋翼與機殼罩及尾管	25

Thank you for purchasing the Thunder Tiger Raptor E550 FBL R/C helicopter. This new helicopter is the latest innovation by Thunder Tiger. It has the perfect combination of flying stability and the agility for 3D flying. This helicopter is an excellent choice for flying enthusiasts like you. For convenient assembly and safe operation of the helicopter, please read the instructions carefully. Retain the user manual in case you need it for any information or reference.

感謝您購買雷虎科技Raptor E550 FBL 直昇機產品，本項產品為雷虎科技全新開發機種，兼具高度穩定性與3D飛行特性，是熱衷引擎直昇機的您不可錯過的選擇。請於使用本產品前詳盡閱讀使用手冊，以利於組裝工作順暢進行與安全操控本產品。請妥善保存使用說明書，以利後續調整與維修參考用途。

## CAUTION / 警告

1. R/C models are not toys. This product is a high-precision flying machine. Possibilities of unexpected crashes may occur due to electronic interference, incorrect operation, or poor mechanical maintenance. Although it is a small-sized helicopter, the rotor blades rotate at high speeds, which may cause serious damage, injury, or death if the model hits people or property. Therefore, extreme caution must be exercised during operation.
  2. Thunder Tiger ensures parts packaged in this product have the highest quality. However, after assembly and usage, parts damaged due to wear or misuse will not be replaced under any circumstances. If you have any questions regarding its operation and repair, Thunder Tiger's service agents are able to provide free technical guidance.
  3. This product is only recommended for users ages 16 and up. Because flying a R/C helicopter is difficult, beginners must receive guidance and supervision from experienced pilots to minimize unexpected danger. Practice in spacious areas, far away from obstacles such as buildings, trees, electrical towers, or crowds.
  4. To decrease the cost of repair and maintenance for beginners, it is recommended to fly the helicopter with a practice rack and to learn basic flying skills with a computer R/C flying simulator. (Crashes in simulators are free to repair!)
1. 本項遙控直昇機產品並不是玩具，是一項結構精密、高專業度模型產品，如果未經正確組裝與操控，將可能對操控者或其他人造成身體傷害。使用者必須了解，若未確實進行飛行前安全檢查或操控不當，而造成人員受傷或物體損壞，使用者必須負起法律責任。
  2. 本產品由高品質零組件組成，雷虎科技對於安裝過程、使用過後...等人為因素造成損壞事件不負損壞賠償之責。如您需要本產品相關組裝、調整或其他協助，可與雷虎科技全省經銷商聯繫。
  3. 本項產品禁止十六歲以下青少年與孩童使用。強烈建議初學者應取得技術支援後再進行飛行，以避免危險發生。請於空曠地區操控本產品，並避免於建築物、樹木、電塔...等障礙物區域飛行。
  4. 建議初學者可安裝練習架或透過電腦模擬軟體練習，可達到實際練習效果與符合經濟效益。

## AMA INFORMATION / 特別注意事項

Operating a model helicopter requires a high degree of responsibility and skill. If you are a newcomer to the hobby, it is best to seek help and guidance from accomplished model helicopter pilots. This will greatly speed up the learning process and make you to fly successfully in a reasonable amount of time. We also would strongly urge you to join the Academy of Model Aeronautics. The AMA is a non-profit organization that provides its members with a liability insurance plan as well as monthly magazine entitled Model Aviation. All AMA charter aircraft clubs require all pilots to hold a current AMA sporting license prior to operation of their models at club fields. For further information, contact the AMA at:

Academy of Model Aeronautics  
5151 East Memorial Drive  
Muncie, IN 47302  
(317) 287-1256

操控遙控直昇機對於飛行安全要求極高，需要高度的負責任態度配合，以及較高的操控技巧。如果您是一位初學者，建議您必須向當地專業模型經銷商，或是遙控直昇機相關組織以及經驗豐富的玩家尋求相關協助，以獲得您所需要的訊息以及專業知識。如此可有效協助您縮短學習的時間，更容易學會遙控直昇機的組裝、設定與操控技巧。

1. Make sure that the transmitter battery is fully charged before flying.
  2. Make sure all control surfaces are operated properly before flying.
  3. Do a range check of the radio before the first flight. The electronic equipment must operate properly at a range of at least 5 meters (18 ft) even with the transmitter antenna collapsed.
  4. Make sure there are no other pilots using the same radio frequency with yours and that there are no other radio interferences on your frequency.
  5. Be sure to turn on the transmitter first with the throttle stick in the idle position. Plug the battery into the ESC last.
  6. The main rotor and the tail rotor spin at very high RPM. Make sure nothing can come in contacting with the rotor blades during flight.
  7. Always maintain a safe distance from the helicopter during flight.
  8. Never fly the helicopter in the rain or in excessive wind conditions.
  9. Always operate and fly the helicopter in a safe and responsible manner.
  10. Never fly the helicopter over other pilots, spectators, cars or anything that could result in injury or property damage.
1. 確認接收機與發射機電池，均已確實充電完成。
  2. 確認所有操控介面運作順暢。
  3. 確認無其他無線電波干擾，且不與其他同好同時使用相同頻率。
  4. 確實將油門搖桿放置於低速，再將發射機電源開啟，然後再將電池接上。
  5. 確認遙控器發射器與接收機工作正常，將機體放至於距離5公尺外，確認遙控器是否正常，機體控制動作是否正確。
  6. 主旋翼與尾旋翼轉速相當高，運轉時須避免任何障礙物與旋翼接觸。
  7. 飛行時，須與遙控直升機保持安全距離。
  8. 勿於下雨天或是強風的狀態下操控遙控直升機。
  9. 請以安全為第一考量，並以高度負責任的態度參與遙控直升機活動。
  10. 禁止於人群、車輛..或任何其他障礙物上方飛行遙控直升機，避免意外發生。

## POST FLIGHT INSPECTION / 飛行結束安全檢查事項

1. Inspect the model thoroughly to ensure no parts have come loose or become damaged during the flight and landing. Replace damaged parts and tighten loose screws before flying again.
  2. Clean the helicopter body.
  3. Lubricate all moving parts to ensure smooth operation for the next flying.
  4. Replace any worn ball links and damaged bearings.
  5. Store the model in a cool, dry place. Avoid putting it under direct sunlight or near a source of heat.
- Following these simple rules will allow you to enjoy the thrill of model helicopter flying for many years.
1. 飛行結束後確認機體所有的零件與螺絲是否有損壞或鬆動，更換損壞零件與確實固定鬆動的螺絲。
  2. 機體清潔乾淨。
  3. 檢查所有活動零組件是否運作順暢，以利下次飛行。
  4. 更換所有鬆動的連桿、接頭，以及損壞的軸承。
  5. 將機體存放於陰涼通風處，避免機體放置於陽光直射處或接近熱源。
- 確實執行上述幾項簡單的步驟，將可確保您的愛機維持數年的壽命！

## CAUTION / 注意事項

When the model crash occurs, inspect the flybar, rotor shaft and the blade spindle to make sure they are not bent. If any item is damaged, it must be replaced with a new part to ensure safe operation. Do not glue any broken or damaged plastic parts. Do not repair broken rotor blades. It is very important to inspect the motor, speed control and the battery.

Always inspect the following items:

Gears, Ball links, Link rods, Bearings, Main shaft, Spindle, Tail boom and support, Fins, Tail rotor shaft, Belt, Main blades, Tail blades, Motor, Speed control and the Battery.

機體一但發生墜落事件，請確實檢查平衡桿、主軸、橫軸是否有彎曲變形，如果有任何的損壞，請立即更換原廠新的零組件，確認機體操作安全！切勿使用任何接著劑嘗試黏合塑膠零件；請勿使用修復過的主旋翼。馬達、速控器、電池的安全檢查工作亦相當重要。

發生機體墜落事件後，請確實檢查下列項目：

齒輪組、球頭連桿、連桿頭、軸承、主軸、橫軸、尾軸、尾管、尾管支撐架、垂直與水平尾翼、尾驅動輪、皮帶、主旋翼、尾旋翼、馬達、速控器、電池。

# CONTENTS INCLUDED / 內容物說明



No.2379-F  
ACE RC Ripper  
OBL44/11-30H Motor  
1,150KV無刷外轉馬達



No.8089  
GT5.2 3AXIS Gyro  
三軸陀螺儀



No.8163  
Tail Servo  
尾舵伺服機



No.8179  
Swash Plate Servos(x3)  
舵面伺服機

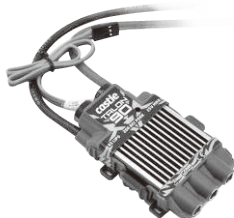

Castle Creations  
Talon 90A  
Speed Controller  
90A電子調速器



No.3934  
550 mm Carbon Blades  
碳槳, 550 mm

# ADDITIONAL ITEMS REQUIRED / 另購配件

## RADIO SET / 遙控系統

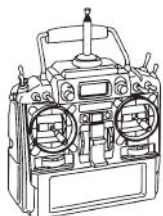

Transmitter (helicopter type,  
6 or more channels)  
發射機 (需具備直昇機控制功能的  
6動以上遙控器)



NiMH/NiCd 4.8V Battery Pack  
1,100mAh+ 外接接收機電池組

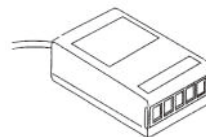

Receiver  
接收機

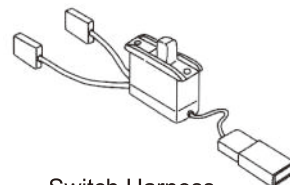

Switch Harness  
具備充電線的開關組

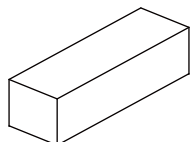

6S Li-Po Battery Pack  
鋰聚電池組

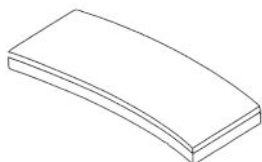

Foam  
雙面膠帶



Pitch Gauge  
螺距尺



LiPo Battery Charger  
鋰電池充電器

# TOOLS REQUIRED FOR MAINTENANCE / 另購維修工具

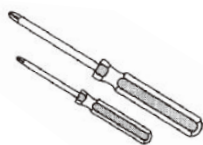

Screw Driver  
各種規格的螺絲起子



Needle Nose Pliers  
尖嘴鉗



Nipper  
斜口鉗

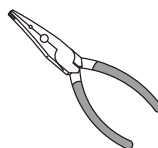

Ball Link Pliers  
拆連桿頭的專用鉗子



Scissors  
剪刀

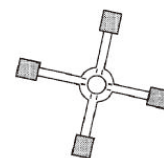

Metric 4-way Wrench  
十字套筒板手

5.5mm  
7mm  
8mm



Hobby Knife  
美工刀



C.A Glue  
瞬間膠

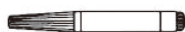

Threadlocker  
螺絲防鬆膠



Grease  
潤滑油



Epoxy  
環氧樹脂

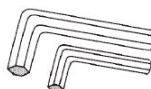

Hex Wrench  
六角板手

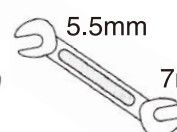

5.5mm  
7mm  
Wrench  
開口板手

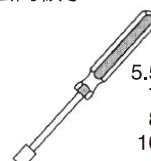

5.5mm  
7mm  
8mm  
10mm  
Socket Drivers  
套筒螺絲起子

The detailed assembly steps are shown from page 15 to 26.  
 詳細組裝圖請參考第15~26頁。

①②③ Assemble in right order  
 依標示順序組裝

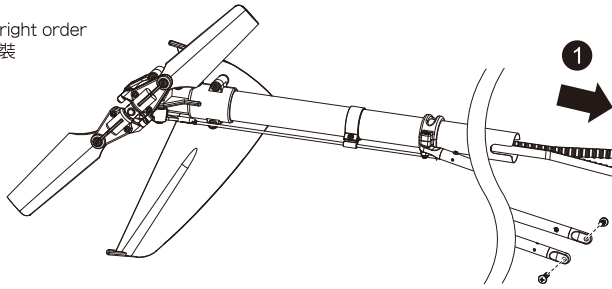

- (1) Insert the tail boom into the boom bracket and push it all the way to the end.  
 將尾管穿入尾管固定座內並推到底。
- (2) Warp the belt onto the autorotation tail drive pulley; note the belt direction of rotation when warping.  
 將皮帶繞過尾驅動輪；注意安裝時皮帶的扭轉方向。
- (3) Gently pull back the tail boom until the tension of the belt allows less than 5 mm (3/16") of free play in the belt.  
 慢慢地將尾管向後拉緊，直至按壓皮帶時，間隙小於5 mm (3/16") 為最佳。
- (4) Move the tail boom supports bracket and metal clip to their proper positions, and then tighten the screws to avoid unexpected invagination of tail boom.  
 將尾管支撐架及止擋環定位，並鎖緊螺絲，以防止尾管內縮。
- (5) Secure all other screws tightly and mount the blades.  
 鎖固所有的其他螺絲並安裝上旋翼。

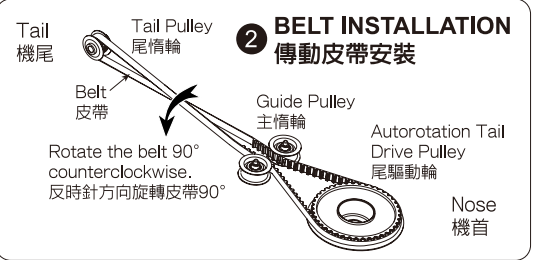
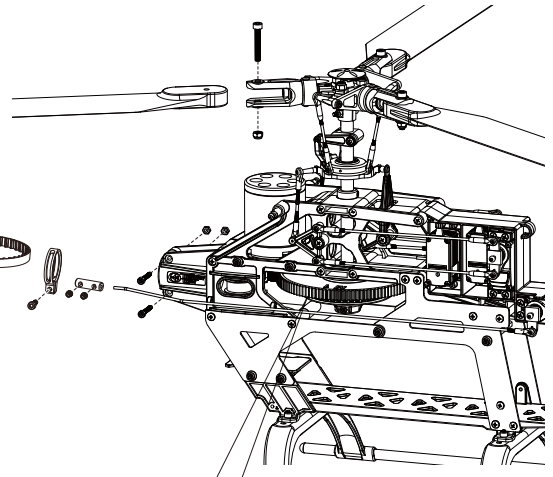

## DEVICE CONNECTION / 設備連接說明

The wire connection between devices and receiver may differ in different brand of radio system. The figures below are for your reference, please read your radio system manual to find the proper connections.

各品牌遙控系統的電子設備與接收機間接線方法或有差異，以下圖示為安裝範例，實際接線方式請參閱您的遙控器說明書。



Although the Speed Controller (ESC) comes with the ARF featuring a 5.5V BEC, to connect an additional receiver battery pack could avoid any unexpected shutdown of BEC.  
 完成機內附電子調速器具備BEC功能，額外使用一顆接收機電池以可防止BEC意外斷電的情況。(BEC safe措施)

### SPECTRUM (DSM2 / DSMX)

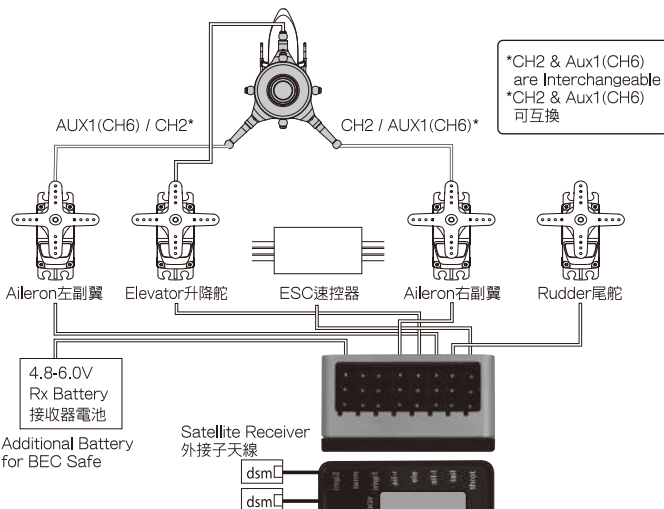

### ACE RC / FUTABA / HITEC

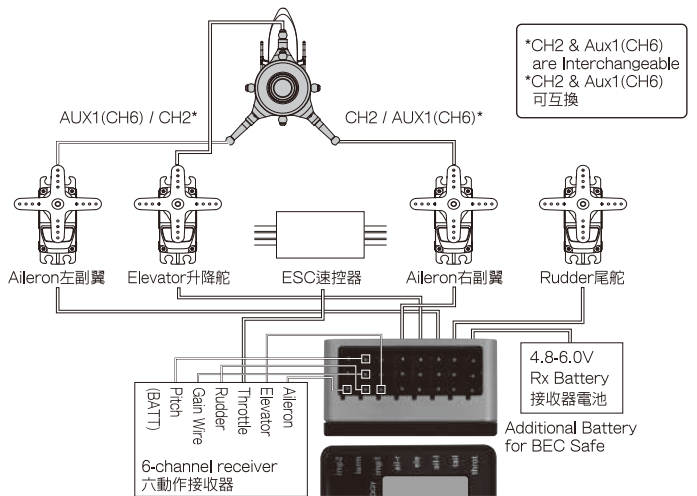

### JR

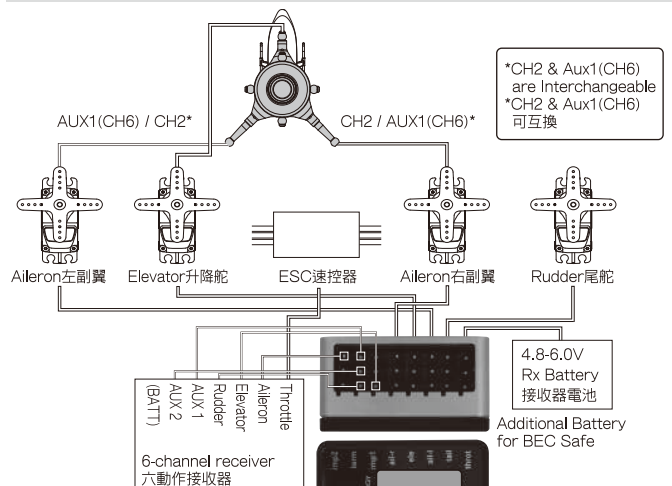

☆ We list some suggested configurations for your reference, note these configurations would be various even you have same configuration, you can also find the best configuration by yourself to fit your own demand.

Attention: Please always try whether these settings work well before you start to fly.

☆ 以下為原廠建議的參數設定值。要注意的是：使用同樣的參數設定，這些設定之間也可能存在着差異。當然，實際使用當中請您選擇最滿足你需要的配置。

注意：在每次飛行之前，請確認陀螺設置是否正常运行。



Be careful! The GT5.2 is a high-tech & performance flybarless control system, and any changes of parameters may cause unexpected situation during flights. Please ensure you had known the functions well before you do any adjustment. It is strongly recommended to seek helps and guidance from accomplished pilot when adjusting the parameters of GT5.2 if you were newcomer to the RC helicopters.

請小心! GT5.2是一項高科技且高性能的無平衡翼控制系統，任何設定值變更都可能造成飛行時出現預期外的動作。請在進行任何設定調整前，務必確定您已對所有功能用途有充份認識。如果您是剛接觸遙控直昇機的初學者，強烈建議您尋求有經驗的玩家協助您調整GT5.2參數值。

## ■ PID Menu 設定功能

Level 選單層		Function Description 功能選項敘述	Suggested Parameters for Initail E550 建議初始值	Level 選單層		Function Description 功能選項敘述	Suggested Parameters for Initail E550 建議初始值
1	2			1	2		
		Stability	80	(Continue from left column...承左欄)			
		Consistency	80			Torque pitch	-30
		Response	5			Torque SW plate	-15
		Stick mix	85				
		Speed stability	28				
		Stability	70				
		Consistency	70				
		Smooth stop	3				
		Stop asymetry	0				

## ■ Swash Plate Menu 十字盤設定功能

Level 選單層		Function Description 功能選項敘述	Suggested Parameters for Initail E550 建議初始值	Level 選單層		Function Description 功能選項敘述	Suggested Parameters for Initail E550 建議初始值
1	2			1	2		
		SW freq	166			Servo limit	20
		SW1 subtrim	0	☆		Dir-Elev-Sensor	reverse
		SW2 subtrim	0	☆		Dir-Ail-Sensor	normal
		SW3 subtrim	0				
		Swash type	140				
		SW direction					
		Virtual rotation	0				
		Cyclic Pitch	100				
		Collective Pitch B	70				
		Collective Pitch A	70				

## ■ Tail Menu 尾舵設定功能

Level 選單層		Function Description 功能選項敘述	Suggested Parameters for Initail E550 建議初始值	Level 選單層		Function Description 功能選項敘述	Suggested Parameters for Initail E550 建議初始值
1	2			1	2		
		Tail type	760			Tail limit B	235
		Tail freq	333	☆		Dir-Rud-Sensor	reverse
		Tail subtrim	0	☆		Dir-Pir-Sensor	normal
		Tail limit A	235				

## Stick Menu 撥桿設定功能

Level 選單層		Function Description 功能選項敘述	Suggested Parameters for Initail E550 建議初始值	Level 選單層		Function Description 功能選項敘述	Suggested Parameters for Initail E550 建議初始值
1	2			1	2		
		Trim save				Tail rate	100
		Trim clear				Expo-SW plate	25
		Aileron rate	100			Expo-tail	25
		Elevator rate	100			Stick tolerance	5

## Receiver Menu 接收機設定功能

Level 選單層		Function Description 功能選項敘述	Suggested Parameters for Initail E550 建議初始值	Level 選單層		Function Description 功能選項敘述	Suggested Parameters for Initail E550 建議初始值
1	2			1	2		
		RX type				Fail safe	0

## General Menu 工具

Level 選單層		Function Description 功能選項敘述	Suggested Parameters for Initail E550 建議初始值	Level 選單層		Function Description 功能選項敘述	Suggested Parameters for Initail E550 建議初始值
1	2			1	2		
		Mount				Gyro tolerance	5
		Auto exit	25				
		Reset					
		SW delay level	3				
		Tail delay level	2				

☆ Screen facing up, connector to back

☆ 屏幕朝上，接線在後

1 3 systems of receiver may alternative: Standard Rx, Futaba S-bus or Spectrum Compatible, which depends on the radio system you use. Please refer page 5 of this manual to know the correct device connections according to your radio brand.

2 Only used with Spectrum satellites; please refer your radio instruction manual if using a standard Rx or Futaba S-bus systems to execute binding. To binding a Spectrum Tx and Rx: Activate the menu and both satellite LEDs will flash- placing the GT5.2 into "Bind" mode. Turn on the Tx whilst holding in the bind-button. Binding is completed when the satellite LEDs remain solid.

1 依您所使用的接收機系統選用：標準接收機、Futaba S-Bus或Spectrum相容系統。並依所使用的遙控器品牌正確完成電子設備配線，說明請詳閱本說明書第5頁。

2 僅適用於Spectrum外接子天線；如使用標準接收機或Futaba S-bus系統，請翻閱您的遙控器說明書來執行對頻。

Spectrum對頻程序：進入本功能選單，此時子天線LED燈為快閃狀態，使GT5.2進入“對頻”模式。按住發射機上對頻功能鍵並開啟發射機電源，當子天線上LED停止閃爍時，表示對頻完成。

GT5.2 manual download website:

GT5.2說明書下載網址:

<http://www.thundertiger.com/actions/download/name:Manual/filename:4d189a65e280acdcb04d8967f7bc6d2f.pdf>



To set the Fail-Safe function on your helicopter as well for safety is strongly recommended. Please refer your radio instruction manual to learn how to set the FS function if using a Standard Rx or Futaba S-bus. If using a Spectrum compatible Rx, please refer the GT5.2 manual "Fail-safe Configuration upon DSM2/X".

安全起見，強烈建議您也同時設定“安全回復”功能。如使用標準接收機或Futaba S-bus系統，請翻閱您的遙控器說明書來完成設定。如您使用Spectrum相容系統，請詳閱GT5.2說明書“DSM2/X系統安全回復設定”。



1 The signal directions of vary brand radios may differ, please refer your transmitter instruction manual and page 8 of this manual "SWASHPLATE & SERVO MOVEMENT SETTING" to set the proper directions.

2 The values on this function depends on the specifications of the servos you purchase, any wrong value set here may cause unexpected damage of servos, please inquire the servo manufacture to know the specification in details.(The values here had already pre-set properly at factory for the servos come with E550.)

1 不同品牌遙控系統訊號方向會有所差異，請參考您的遙控器說明書及本說明書第8頁“十字盤及伺服機動作設定”來設定正確的舵機動作方向。

2 本功能內設定值取決於您所使用的舵機規格，任何錯誤設定值都可能造成舵機損壞，敬請向舵機製造商詢問詳細的規格數據。（該值已由原廠針對E550所附舵機正確設定完成。）



# MODEL & SWASHPLATE SETTING / 模型及十字盤模式設定



Set the model type for helicopter in your transmitter and set the swashplate type as 90-mCCPM (mechanical Mixing or 1 servo for each function). Please refer your transmitter manual to find a proper setting.

請將遙控器設定為直昇機模式，並選擇“90-mCCPM”十字盤控制功能。正確的詳細設定，請參閱您的遙控器說明書。

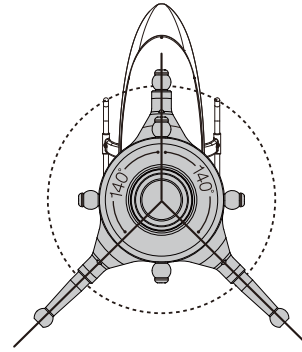

## SWASHPLATE & SERVO MOVEMENT SETTING 十字盤及伺服機動作設定

The movement direction of servo may differ in different brand of radio system; Power on your transmitter and receiver, please refer the figure below to ensure the direction of swashplate and servo movement are correct, as well as observe if there is any bind or interference when the servo reaches to the maximum travel point.

各品牌遙控系統伺服機方向訊號或有不同，請依序開啟發射機及接收機，參閱以下圖示確認十字盤及伺服機作動方向正確，同時觀察伺服機作動達最大行程量時，是否有行程量過大或干涉情況。

	Mode 1	Mode 2	Servo Horn movement 伺服機擺臂動作		Check Point 機構動作確認
Aileron 副翼			Right Side/右側 	Left Side/左側 	Front View / 前視圖 
Elevator 升降舵			Left Side/左側 		Right View / 右視圖 
Pitch 螺距			Right Side/右側 	Left Side/左側 	Front View / 前視圖 
Rudder 尾舵			Right Side/右側 		

If the movements of servos or swashplate are incorrect, please refer your transmitter manual to turn on the “Servo Reverse” function for one or more channels in your transmitter.

If there's any bind or interference when reaching the maximum servo travel point, please also refer your transmitter manual to reduce the “Travel Adjustment (or End Point Adjustment)” value in your transmitter.

如伺服機或十字盤動作方向錯誤，請參閱您的遙控器說明書，開啟遙控器上的伺服機逆轉功能。

如伺服機最大行程量過大或發生干涉，請參閱您的遙控器說明書，降低伺服機行程量設定值。



For safety, to set a Fail Safe function per your transmitter instruction manual at this step is strongly recommended.

安全起見，建議您參閱遙控器說明書，在此步驟中同時設定“安全回復”功能。

## Lengths of Linkage Rods 連桿長度設定值

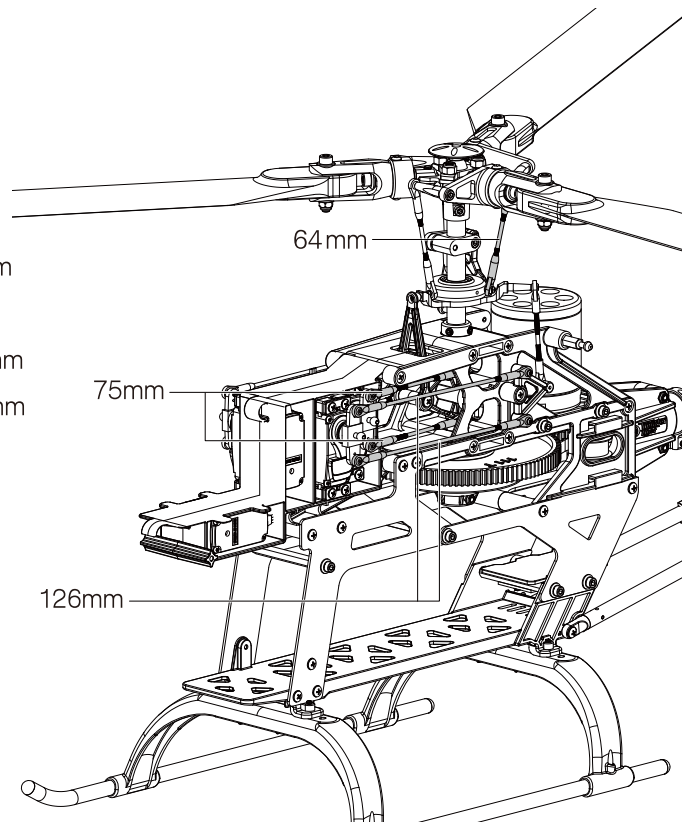
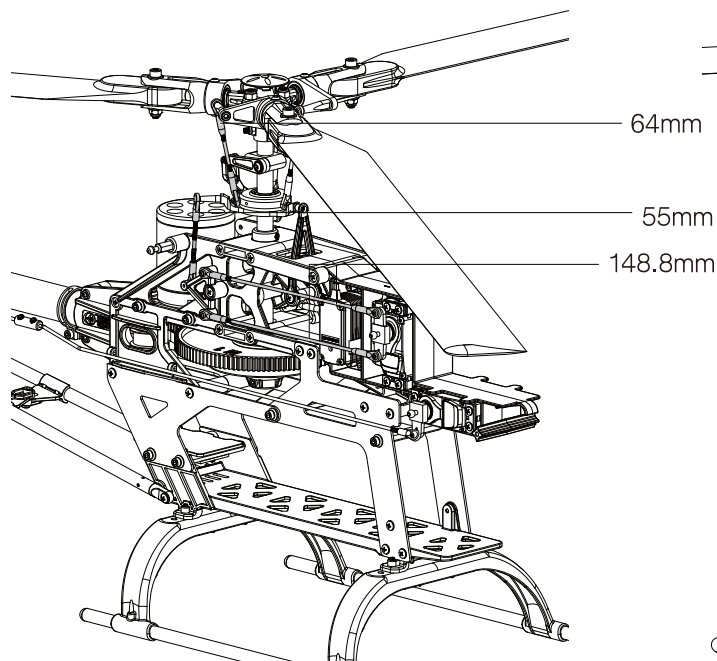

The proper lengths of linkages on the helicopter have been setup correctly at Factory, but may need to be slightly adjusted per the actual conditions.

直昇機上連桿已由原廠組裝完成，但長度可能仍需視實際情況略做調整。



Length measured from ball link center to ball link center

由此連桿頭中心測量至另一頭連桿頭中心

## Servo Neutral Position 伺服機中立點

Adjust the Pitch and Throttle Curves as a  $-45^\circ$  straight line (from 0 to highest 100% and pass through the mid-point 50%) on your transmitter firstly. Refer the figure below to ensure every servo is at its neutral positions when the sticks of transmitter are at its neutral position before setting the corrective pitch. Refer your transmitter manual to adjust the "Sub-Trim" values if the servos are not at its neutral position.

首先將油門曲線設定為負斜率之對角線。參閱右圖，確認所有伺服機皆正確對應遙控器撥桿中立點位置。如果伺服機偏離中立點，請參閱您的遙控器說明書使用 "Sub-Trim" 進行微調。

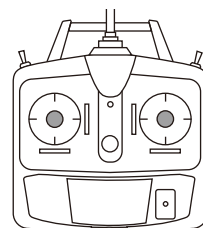

Both Stickers are at their neutral positions. 撥桿皆位於中立點位置

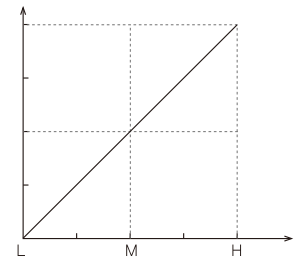

[Pitch / Throttle Curve]

Point L : 0%

Point M : 50%

Point H : 100%

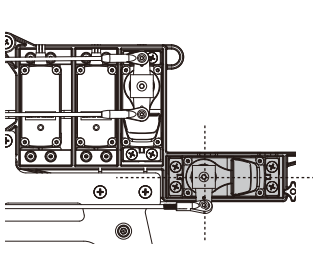

Tail Servo  
尾舵伺服機

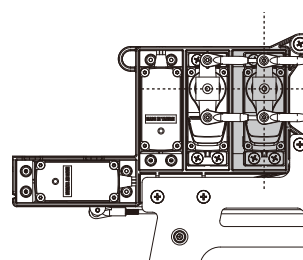

Elevator Servo  
升降舵伺服機

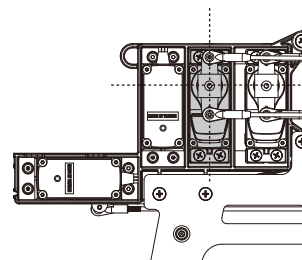

Pitch Servo  
螺距伺服機

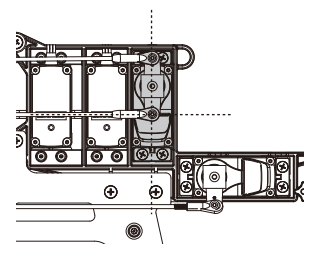

Aileron Servo  
副翼伺服機

## COLLECTIVE PITCH RANGE SETTING / 螺距範圍設定



All linkages and servos should be at their neutral positions if you have done the adjustment correctly per the description above. The steps below will define the limits of the collective pitch setting.

正確依照上述完成設定，所有連桿及伺服機皆應會位於其中立點位置。以下步驟將設定主旋翼螺距的範圍值。



A pitch gauge (available separately) may be required to measure the accurate collective pitch.  
使用螺距尺（另購）才能精確量測聚合螺距攻角。

### Centering 中立點

1. The elevator and aileron control levers should be as the drawing right while centering the collective pitch stick.
2. The main blades and the swashplate should be level.  
1. 當發射機螺距撥置中時，升降舵面及副翼控制搖臂位置應成水平狀態。
2. 主旋翼與十字盤為水平狀態。

### Maximizing 最大螺距設定

1. Place the collective stick at high end.
2. The main blades should be at +13 degree and the swashplate should be level.  
1. 將發射機螺距撥上推至最高點。
2. 主旋翼相對於穩定翼呈+13度角，且十字盤為水平狀態。

### Minimizing 最小螺距設定

1. Place the collective stick at low end.
2. The main blades should be at -13 degree and the swashplate should be level.  
1. 將發射機螺距撥上撥至最低點。
2. 主旋翼相對於穩定翼呈-13度角，且十字盤為水平狀態。

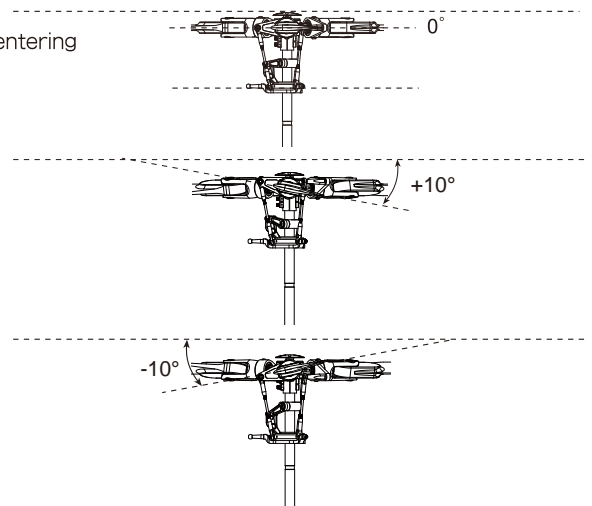

### CAUTION / 警告

The setting of the maximum collective pitch depends on your personal flying skill and style. Too much collective pitch could overload the engine and drive system.

請依個人飛行技巧及習慣來設定最大螺距。過大的角度會增加引擎及傳動系統的負荷而縮短壽命。

## TAIL AND GYRO SETTING / 尾舵及陀螺儀設定

The Gyro and the servo horn have been mounted on the helicopter at Factory. To power off the receiver and then transmitter before we start to set gyro and tail at this step. 陀螺儀及伺服機擺臂已由原廠安裝完成。在開始設定陀螺儀及尾舵前，請依序關閉接收機及遙控器電源。

### Gyro Operating Direction 陀螺儀作動方向

Power on your transmitter then the receiver, do not move the helicopter at this moment until the LED indicator is steady. Check the directions below:

1. While giving the right rudder control, the servo arm should move toward the nose of helicopter.
2. Rotate the helicopter with your hand counter clockwise, the servo arm should move toward the nose of helicopter.

Please switch the direction on your transmitter or gyro if any wrong.

再次依序開啟遙控器及接收機，此時請勿移動直昇機，直到陀螺儀上燈號恆亮為止；確認方向：

1. 當執行右舵時，伺服機擺臂應朝機頭方向作動。
  2. 將整台直昇機逆時針旋轉時，伺服機擺臂應朝機頭方向作動。
- 如方向有誤請切換遙控器或陀螺儀正逆轉方向。

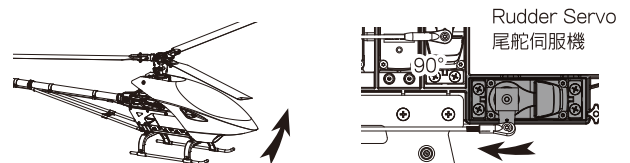

### Length of Tail Linkage Rod 尾舵拉桿長度

The servo horn should be at neutral position while the tail sticker of transmitter is centered, and the pitch of tail rotor grips should be at 0-degree or a little bit offset to right. Please adjust the linkages if the length of rod is incorrect.

當遙控器尾舵撥桿置中時，伺服機擺臂也應位於中立點位置，且尾旋翼螺距為0度，或稍偏向右。如拉桿長度不正確，請調整球頭。

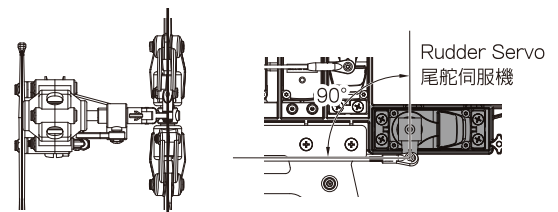

The traveling limit of the tail servo may not go beyond the mechanical movement.

To adjust the traveling limit or pirouetting speed of the helicopter, please use the "Travel Adjustment", "D/R" or "EXP" functions on your transmitter. Refer your transmitter or gyro instruction manual may get more detailed information.

尾舵伺服機最大行程量切勿超過機械行程量。要調整行程量或尾舵自旋速度，請使用遙控器上“行程設定”，“大小動”或“指數值”功能。請詳閱您的遙控器說明書以獲得更多資訊。

## CAUTION / 警告

To connect the Lipo battery pack to ESC is necessary at this step. For safety, please ensure the motor has been deactivated (or disengage the pinion gear from the main gear), and will not drive the main rotor before performing this step!

在此設定程序中，必需將鋰電池連接至電子調速器。安全起見，請再次確認馬達不會被啟動（或將馬達齒脫離主齒盤），且不會驅動主旋翼。

All the parameters of the ESC (Electric Speed Controller) had been set at Factory, the only setting you need to do is the Throttle Calibration:

電子調速器各項參數已由原廠內建完成，您只需進行油門校正程序即可：



The calibration procedure always must be preformed if a new transmitter is being used.  
當新使用，或更換遙控器時，請務必執行校正程序。

1. Power on the transmitter and set the throttle channel full & idle position's ATV value to 25% , then place the throttle stick at full throttle position.  
開啟遙控器，將油門通道ATV最大行程與最小行程設定為25%，並將油門撥桿置於全油門位置。
2. Connect Lipo battery pack to ESC and wait for 2 seconds.  
將鋰電池組（另購）連接至ESC，等待2秒。
3. You will hear several Beep- tones from ESC and increase throttle channel full position's ATV value until another short Beep- tones which means the full throttle position has been calibrated.  
ESC會發出若干聲“嗶”響，此時調整油門最大行程ATV數值至ESC發出1聲“嗶”響，表示全油門位置已完成校正記錄。
4. Move the throttle stick to the idle position (lowest position) , you will hear 1 short Beep- tones from ESC and increase throttle channel idle position's ATV value until another short Beep- tones which means the idle throttle position has been calibrated and ESC is ready to go.  
將油門撥桿置於低點位置，ESC會發1聲“嗶”響，此時調整油門最小行程ATV數值至ESC發出1聲“嗶”響，表示最低點油門位置已完成校正記錄，此時ESC已完成校正程序並已可正常使用。
5. Disconnect the Lipo battery pack from ESC then your transmitter.  
斷開鋰電池組與ESC間的連接，然後關閉發射機電源。



Please refer the ESC instruction manual to read more detailed information if any default settings need to be changed.  
如有任何設定需要變更，敬請參閱電調說明書以獲得更詳細的資訊。

## CAUTION / 警告

Congratulates all the setting on the grand had been done for now. Next section of setting will be moved on the flying field and need to take your helicopter off. Therefore, it is strongly recommended to seek helps and guidance from accomplished pilots if you were a newcomer to the RC helicopters!

至此，您已完成所有的靜態設定。下一步設定需要至飛場進行，並將直昇機升空，如果您是剛接觸模型直昇機的初學者，我們強烈建議您尋求有經驗的玩家給予協助及指導！

The following is the setting up data of pitch curve and throttle curve for your reference only. Please ask experienced pilot to help you if you have never done this before.

下列參數設定僅供參考，請依實際狀況進行調整，或詢求有經驗的玩家協助。

## Beginner / 一般飛行

### Throttle Curve 油門曲線

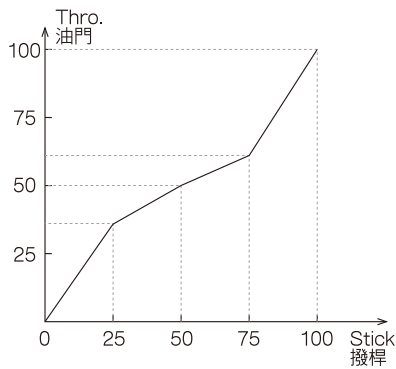

### Pitch Curve 螺距曲線

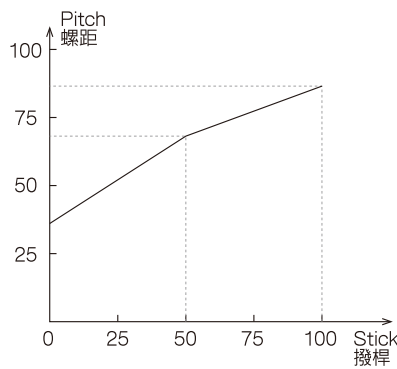

### Throttle Curve 油門曲線

	0	25	50	75	100
Normal 一般飛行	0	35	50	65	100

### Pitch Curve 螺距曲線

	0	25	50	75	100
Normal 一般飛行	35	-	70	-	85

### Pitch Curve 螺距曲線

	0	25	50	75	100
Normal 一般飛行	-4°	-	+6°	-	+10°

## 3D

### Throttle Curve 油門曲線

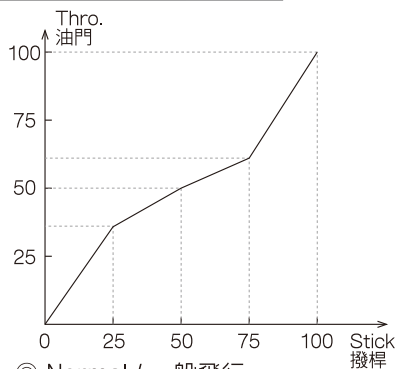

◎ Normal / 一般飛行

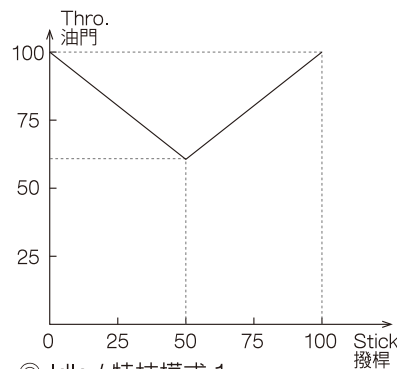

◎ Idle / 特技模式 1

### Throttle Curve 油門曲線

	0	25	50	75	100
Normal 一般飛行	0	35	50	65	100
Idle-up 1 特技模式 1	100	-	60	-	100

### Pitch Curve 螺距曲線

	0	25	50	75	100
Normal 一般飛行	35	-	70	-	85
Idle-up 1 特技模式 1	0	-	-	-	100
Hold 鎖定模式	0	-	-	-	100

### Pitch Curve 螺距曲線

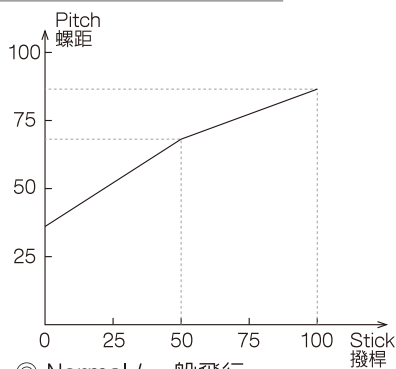

◎ Normal / 一般飛行

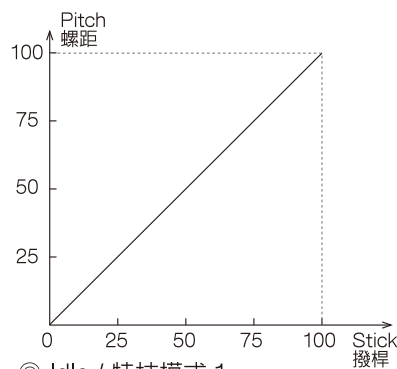

◎ Idle / 特技模式 1

### Pitch Curve 螺距曲線

	0	25	50	75	100
Normal 一般飛行	-4°	-	+6°	-	+10°
Idle-up 1 特技模式 1	-10°	-	-	-	+10°
Hold 鎖定模式	-10°	-	-	-	+10°

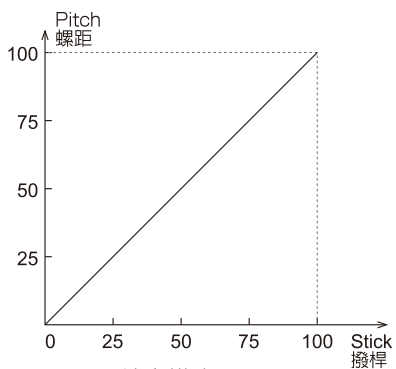

◎ Hold / 鎖定模式

## ⚠ WARNING 警告

1. Too much collective pitch will bring about too much loading to the motor and drive system.
  2. Too much headspeed will lead to blades (grips) explosion.
  3. It's very dangerous for setting the headspeed over the blades (grips) limit.
  4. Please do not set the collective pitch to the maximum ( $\pm 15$ ) unless you have very good collective pitch management skill.
1. 過大的聚合螺距設定會使馬達及傳動系統超載。
  2. 過快的主旋翼轉速會造成主旋翼轉座崩裂或射槳。
  3. 將旋翼轉速設定超過槳片負載極限極端危險!
  4. 請勿將聚合螺距設定超過最大值 (+15度角)。

## ⚠ CAUTION / 警告

For safety, ensure to keep a safe distance from the helicopter at least 10 meter (30 feet) while making tracking adjustment.

安全起見，進行主旋翼軌跡調整時，請至少與直昇機保持10米（30呎）的安全距離。

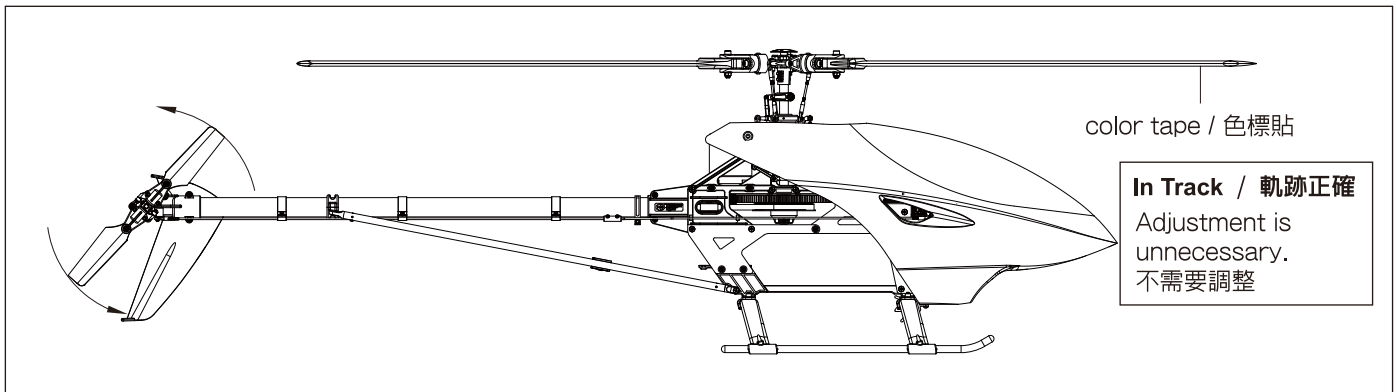
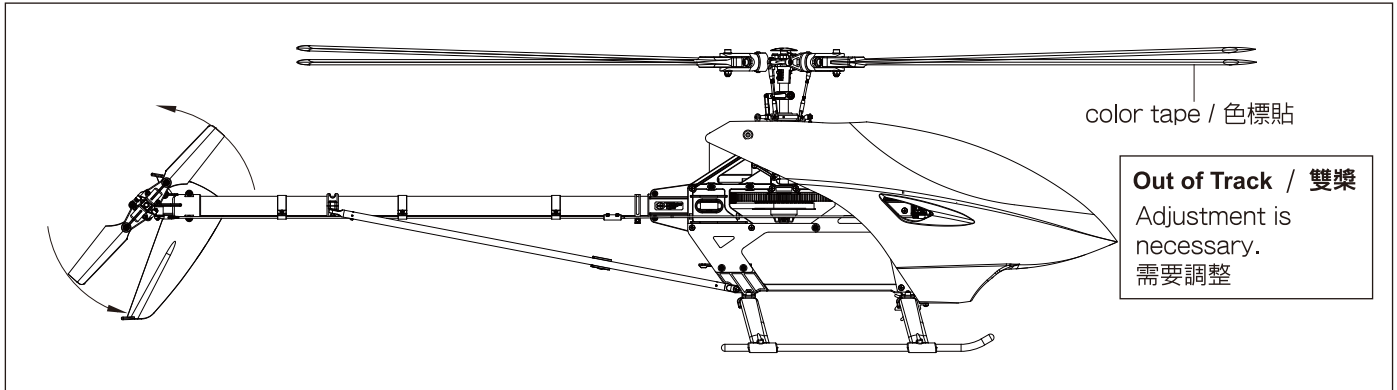

1. Use a color tape at the tip of main blades for tracking identification easily.
2. Increase the main blade speed for slight lift-off.
3. Observe which blade appears to be lower than the other, and increase the pitch of the lower blade for one turn of the Linkage Rod A at a time until each blade runs in track.

1. 在主旋翼前端貼上色標可方便辨識軌跡。
2. 提高主旋翼轉速使機體稍懸浮於地面。
3. 觀察旋翼軌跡是否有落差（雙槳），調整軌跡較低旋翼上的連桿A長度，一次調整一圈，直至旋翼軌跡一致。

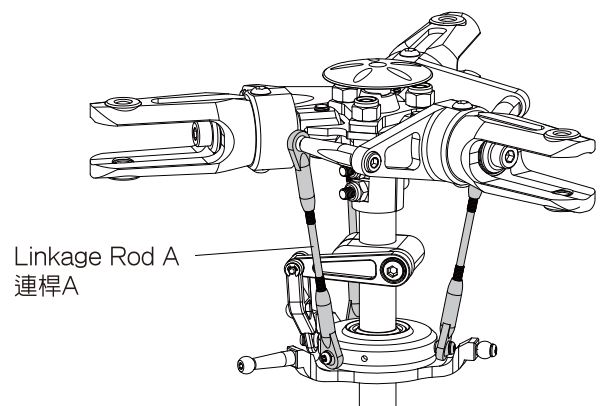

## ⚠ CAUTION / 警告

Out of track will cause vibration, instability and a loss of power due to additional drag. Please adjust the tracking repeatedly until the blades are in track properly.

旋翼軌跡落差（雙槳）會造成直昇機震動、不平衡及損失動力。請務必進行調整以使旋翼軌跡精準正確。



Congratulates all the setting for your helicopter have been done and ready to fly right now. It is strongly recommended to seek helps and guidance from accomplished pilots if you are a newcomer to the RC helicopters! 恭喜您已完成直昇機所有設定並可準備起飛。如果您是剛接觸模型直昇機的初學者，我們強烈建議您尋求有經驗的玩家給予協助及指導！

## CAUTIONS OF Li-Po BATTERY PACK USING / 鋰聚電池使用注意事項



Lithium Polymer (Li-Po) battery is volatile. Failure to read and follow the safety instructions or the instruction manual offered by manufacturers may result in fire, personal injury and damage to property if charged or used improperly.

Please READ your Li-Po battery manual thoroughly before using. Some precaution and information for your reference below:

1. ONLY use a charger specifically designed for Li-Po battery packs to charge/discharge your Li-Po battery packs. Failure to use an improper charger may cause a fire, which may result in personal injury and property damage.
2. A parallel charging process is strongly recommended, otherwise, the balancer is necessary if using a serial charging process.
3. Gernally DO NOT over charge the battery over the maximum voltage of 4.2V/per cell and over discharge drop below 3.7V/per cell.
4. Always keep the voltage of each cell at 3.8V if the pack will be stored for a long term.
5. Always avoid any puncture of the battery pack.

Neither Thunder Tiger nor our distributors/retailers assume liability for failures to comply with these cautions, safety recommended and instruction manual. Users assume all risks associated with Li-Po battery packs.

鋰聚電池具有相當之危險性。疏於詳閱以下注意事項及電池廠商所提供的說明書，或未依據正確操作方式使用，可能會引發火災、人身傷害及財產損失。

請務必在使用前詳閱並遵守使用說明。以下注意事項及訊息提供您參考：

1. 請務必使用鋰聚電池專用充電器充/放電鋰聚電池組。使用不正確的充電器可能會引發火災、人身傷害及財產損失。
2. 強烈建議使用平行充電式的充電器充電。若使用串充方式請務必加裝平衡器。
3. 請勿過度充電使電壓超過4.2伏特/單一電池蕊，或過度放電使電壓低於3.7伏特/單一電池蕊。
4. 如需長期儲存電池，請保持單一電池蕊電壓在3.8伏特。
5. 任何情況下，皆勿擠壓電池。

雷虎科技或授權經銷商/模型店對未依照正確方式使用或安並規定之意外具免責條款，使用人應自負使用鋰聚電池所可能衍生的風險。

## AFTER FLIGHT CHECKLIST / 飛行後的檢查項目

- (1) Check every screw and bolt to make sure none has loosened due to vibration.
  - (2) Check every rotating and movable part to ensure they still move smoothly and normally.
  - (3) Clean off the whole helicopter.
  - (4) Check all movable parts, such as gears, ball links, etc. for unusual wear.
- (1) 每次飛行後必須詳細的檢查機體的各部位螺絲有無鬆動情形，若發生鬆動必須確實鎖緊再進行下飛行。
  - (2) 每次飛行後檢查每一個轉動部位（含單頭連接桿）均能順暢的運作。
  - (3) 直昇機本體必須確實的清潔。
  - (4) 檢查每一個動作部位，齒輪、球頭等是否有不正常磨損。

## REGULAR MAINTENANCE / 定期保養事項

### **Warning! / 警告!**

Lack for regular maintenance or apply a wrong type of grease/oil onto the parts may cause damage and model crash, which may cause series injury or death if the model hits people or property.

疏於定期保養，或塗抹不正確類型的潤滑油皆可能損壞零件造成摔機，因而導致人員受傷或財產損失。

For safety, to check and maintain the parts every 5-10 flights is strongly recommended. Please re-apply the proper grease or oil onto the gears as the illustrations.

強烈建議您每飛行5~10趟需執行下列定期保養事項。請依圖示說明重新在齒輪上塗抹潤滑油。

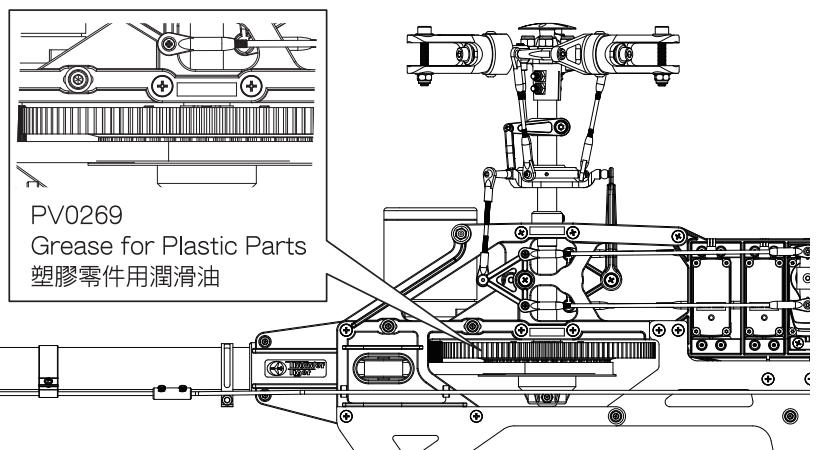



Add a drop of threadlocker on the thread of screws when securing into the parts which are made of metal.  
螺絲鎖固於金屬製品零件時，請酌沾適量防鬆膠。

## CAUTION / 警告

Always do the Pre-flight or Post-flight check on the main rotor plate (PV6319) for safety. Replace a new plate immediately once it is bent, rusted, deformed or any other slightly damaged. Change the plate occasionally to avoid any potential of metal fatigue is strongly recommended.

請飛行前務必檢查確認主旋翼固定片 (PV6319)。如有彎曲、變形或其他輕微損傷，請立刻更換新品以確保飛行安全。

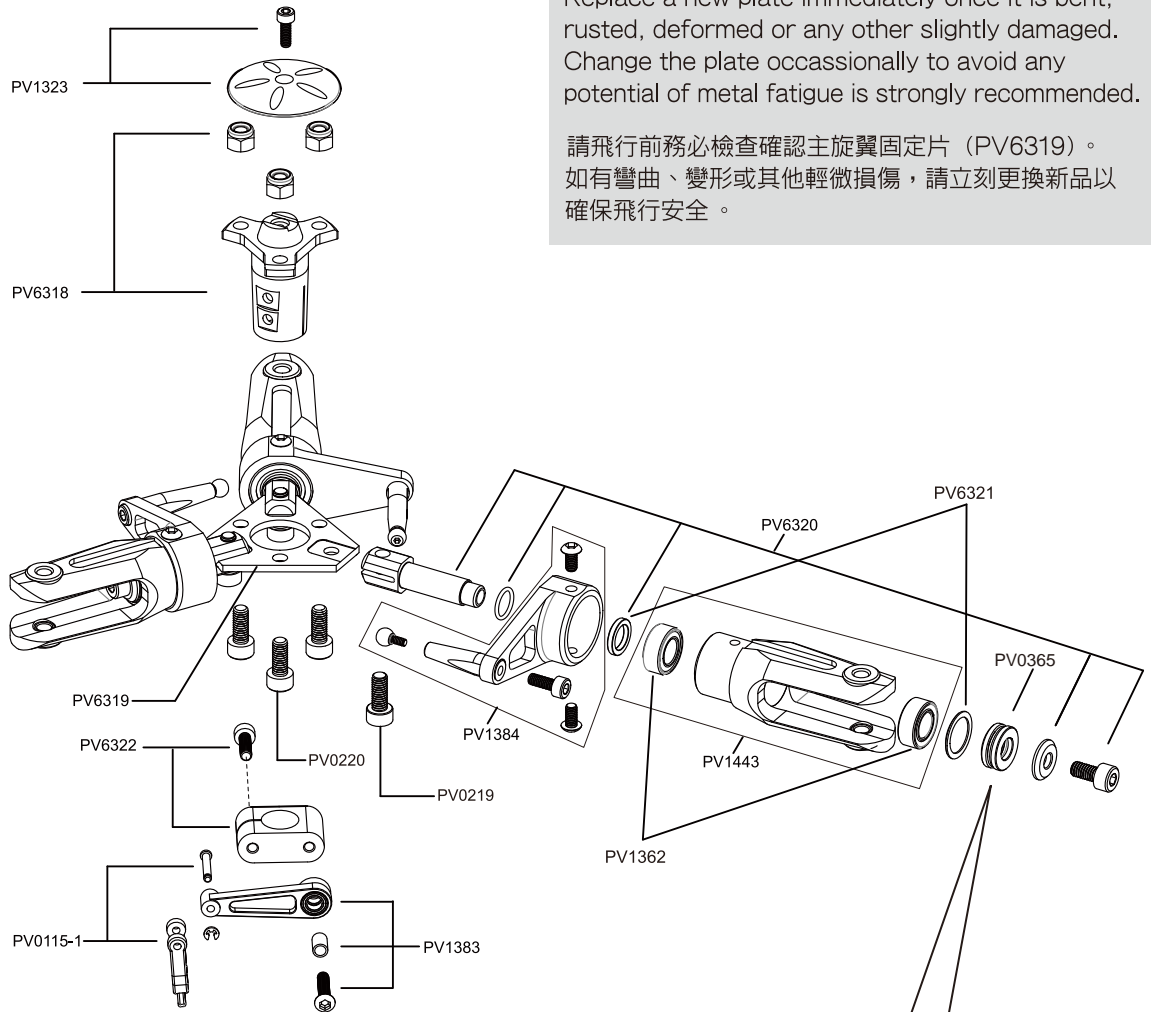

### Diagram for Thrust Bearing Assembly 止推軸承安裝示意圖

Large Internal Diameter  
always go toward the  
Main Rotor Hub  
內徑較大的一側，面向主  
旋翼中心座組（內側）。

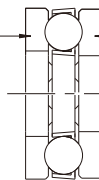

Small Internal Diameter  
always go toward the  
Blade  
內徑較小的一側，面向  
主旋翼組（外側）。

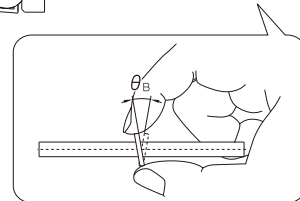
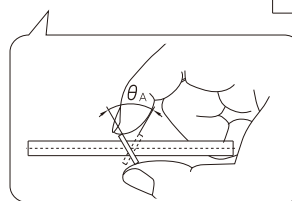

Checking Tips :  $\theta_A > \theta_B$   
轉動角度 :  $\theta_A > \theta_B$   
(轉動角度大者，內孔大；轉動角度小者，內孔小)



Apply grease  
使用潤滑油膏(矽油)



Apply threadlocker  
使用螺絲防鬆膠



Hint  
組裝提示



Ensure smooth, non-binding  
movement when assembling  
確認組件靈活度



Assemble left and right side  
the same way  
左右側組件相同



# SPARE PARTS LIST / 維修零件包表格



No.	Description	中文名稱	Note
PV0115-1	WASHOUT LINK	連接座	
PV1323	METAL HEAD BUTTON	金屬旋翼頭制動器	SOCKET SCREW(M2.5x8)x1
PV1362	SPINDLE BRG. SET (7mm) d7xD13xW5(2)	固定軸軸承組 (7mm), d7xD13xW5(2)	NYLON NUT(M3x2), PART-THREAD SOCKET SCREW(M3x20)x2
PV1383	FLYBARLESS METAL CONTROL LEVER SET	無平衡翼金屬控制搖臂組	SOCKET SCREW(M3x8)x2
PV1384	FLYBARLESS METAL ROTOR GRIP LEVER SET	無平衡翼金屬轉座擺臂組	
PV1443	METAL MAIN ROTOR GRIP	金屬旋翼轉座 (本體)	
PV0219	SHCS M. SCREW(20)M4*10	內六角螺絲, M4*10	SOCKET SCREW(M4*10)*20
PV0220	SHCS M. SCREW(20)M4*12	內六角螺絲, M4*12	SOCKET SCREW(M4*12)*20
PV0365	THRUST BEARING, d6xD12xW4.5	止推軸承組, d6xD12xW4.5	
PV6318	MAIN ROTOR HUB	主旋翼固定座	SOCKET SCREW(M4*10)*3 NYLON NUT(M4)*3
PV6319	MAIN ROTOR PLATE	主旋翼固定片	SOCKET SCREW(M4*10)*3 NYLON NUT(M4)*3
PV6320	SPINDLE	固定軸	SOCKET SCREW(M4*8)*3 FLAP COLLAR(d7*D10 *W1.5)*3
PV6321	WASHER SET	墊片組	FLAP COLLAR(d7*D10*W1.5)*3 THRUST WASHER(d10*D13*W0.5)*3
PV6322	RADIUS ARM BRACKET	相位器固定座	SOCKET SCREW(M3*10)*1

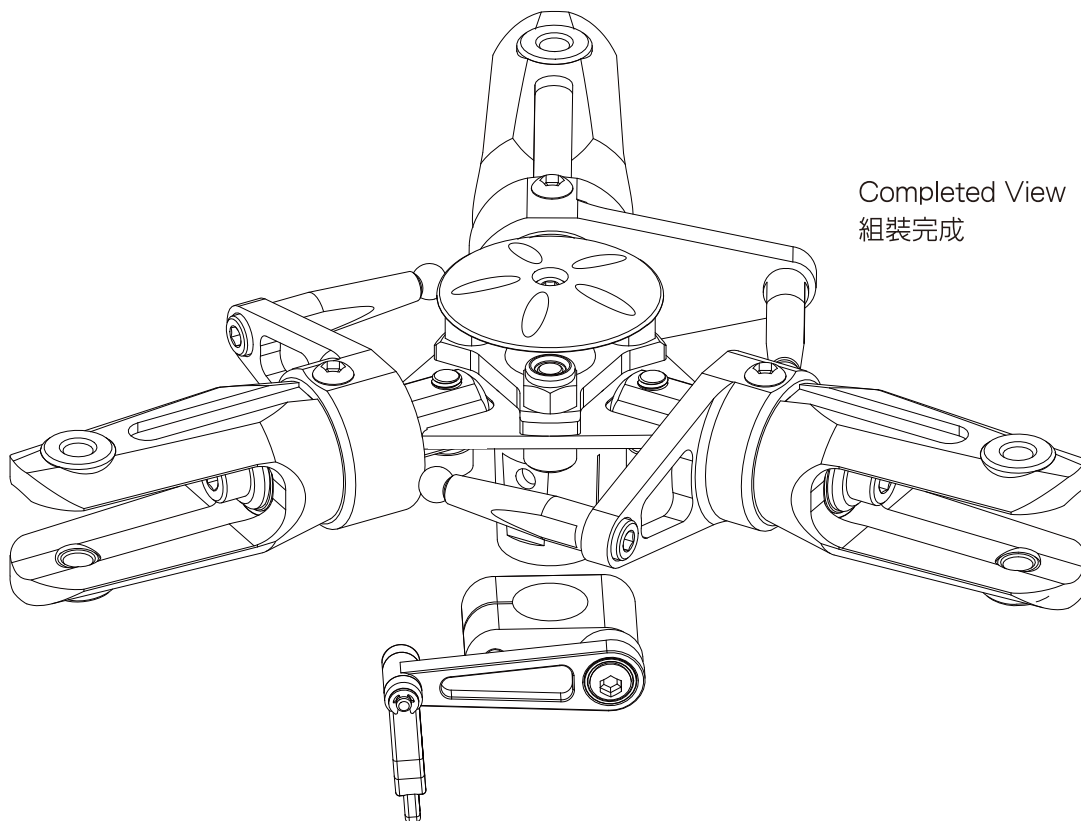

Completed View  
組裝完成

# MAIN FRAME(LANDING SKID) 本體(腳架)



Add a drop of threadlocker on the thread of screws when securing into the parts which are made of metal.  
螺絲鎖固於金屬製品零件時，請酌沾適量防鬆膠。

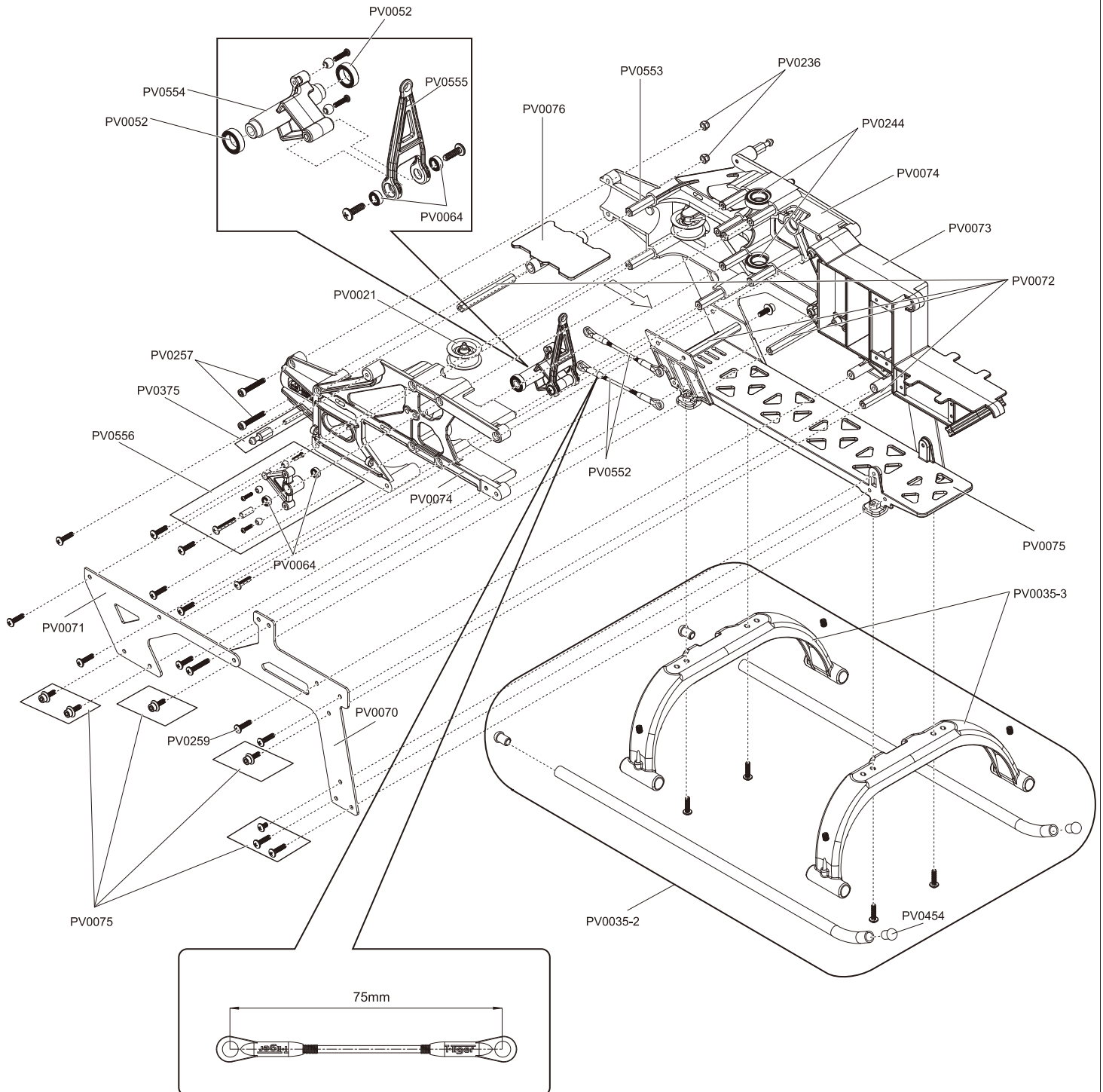

Hint  
組裝提示



Assemble left and right side  
the same way  
左右側組件相同



Apply threadlocker  
使用螺絲防鬆膠

# SPARE PARTS LIST 維修零件包表格



No.	Description	中文名稱	Note
PV0021	GUIDE PULLEY ASSYEMBLY	主惰輪	PIN (D3*L17.8) X1
PV0035-2	LANDING SKID SET	腳架組	SOCET SCREW(M3*14)X4, SET SCREW (M4x5)
PV0035-3	LANDING SKID	腳架	SOCET SCREW(M3*14)X4
PV0052	BALL BEARING(d6*D10*W3)	軸承組	
PV0064	BUSHING(d4*D7*W2.5)X4	銅襯組	
PV0070	CARBON LOWER FRAME FRONT(2)	碳纖下側板(2)-前	
PV0071	CARBON LOWER FRAME REAR(2)	碳纖下側板(2)-後	
PV0072	METAL FRAME SPACER (4)	金屬側板支柱(4),52mm	
PV0073	SERVO TRAY	伺服機座	SELF TAPPING SCREW(M3*12)X6(M3*18)X2
PV0074	MAIN FRAME SET	上側板組	NYLON NUT(M3), SELF TAPPING SCREW(M3*12)X18, (M3*18)X2
PV0075	BUTTON FRAME	電池座下底板	SOCKET SCREW (M3*10)X6,SELF TAPPING SCREW(M3*12)X4,(M3*5)X2,WASHER(d3xD8xW1.4)X6
PV0076	ESC TRAY	速控器固定架	
PV0210	WASHER (d3*D8*W1.4)	墊圈	
PV0236	LOCK NUT,M3	止鬆螺帽,M3	
PV0244	BALL BEARING(d10*D19*W5)	軸承組	
PV0257	SOCKET SCREW,M3x20	內六角螺絲	
PV0259	BUTTON PHILLIPS TAPPING SCREW,M3x12	扁圓型自攻螺絲,M3x12	
PV0375	BODY RETAINING SET	機身固定支柱	SET SCREW(M3x18.5)X2
PV0454	SKIP PIPE CAP	圓管塞	
PV0552	LINKAGE ROD	連接拉桿組	30mmX2 , 46mmX2 ,76mmX2 ,107mmX2 ,130mmX2
PV0553	FRAME SPACER	側板支柱	
PV0554	ELEVATOR ARM LEVER	升降舵控制座	SELF TAPPING SCREW(M2*10)X2
PV0555	ELEVATOR A. ARM	升降舵A型搖臂	
PV0556	AILERON LEVER	副翼控制搖臂	COLLAR(d3*D4*10)X2, SELF TAPPING SCREW(M2*10)X6
*PV0569	METAL ELEVATOR A ARM	金屬升降舵A型搖臂	OPTIONAL PARTS
*PV0668	METAL GUIDE PUILEY ASSEMBLY,RED	金屬主惰輪(紅)	OPTIONAL PARTS
*PV0668-1	METAL GUIDE PUILEY ASSEMBLY,SILVER	金屬主惰輪(銀)	OPTIONAL PARTS

\* Indicating the parts are optional parts and not come with this product.

\* 該零件為改裝品且不包含於本產品中

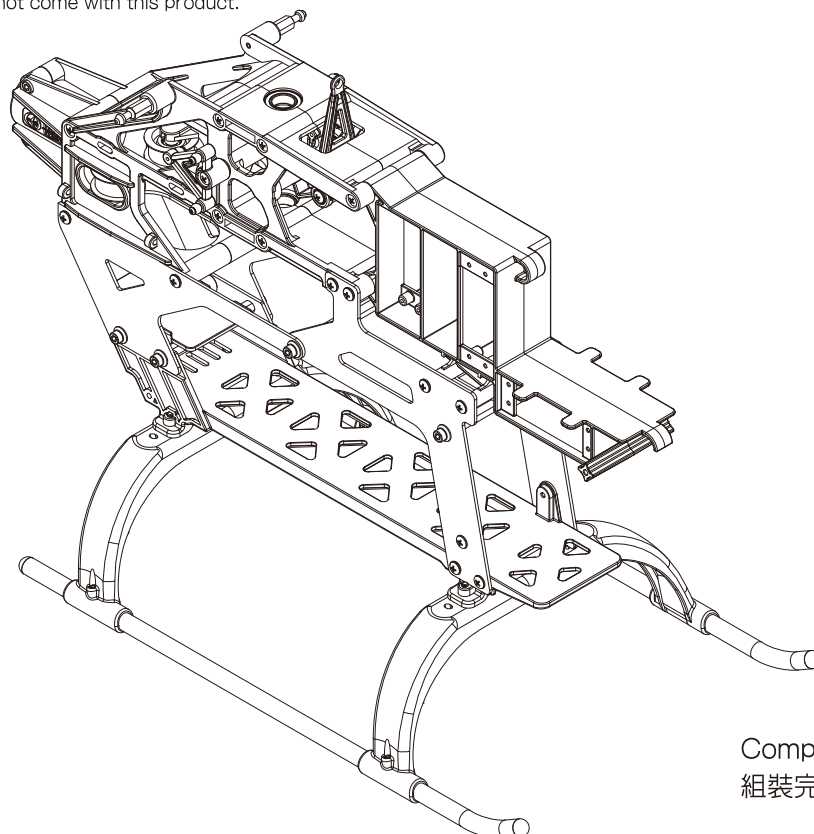

Completed View  
組裝完成

# MAIN GEAR & ROTOR HEAD LINKAGE ROD 主齒輪與主旋翼頭連桿



Add a drop of threadlocker on the thread of screws when securing into the parts which are made of metal.  
螺絲鎖固於金屬製品零件時，請酌沾適量防鬆膠。

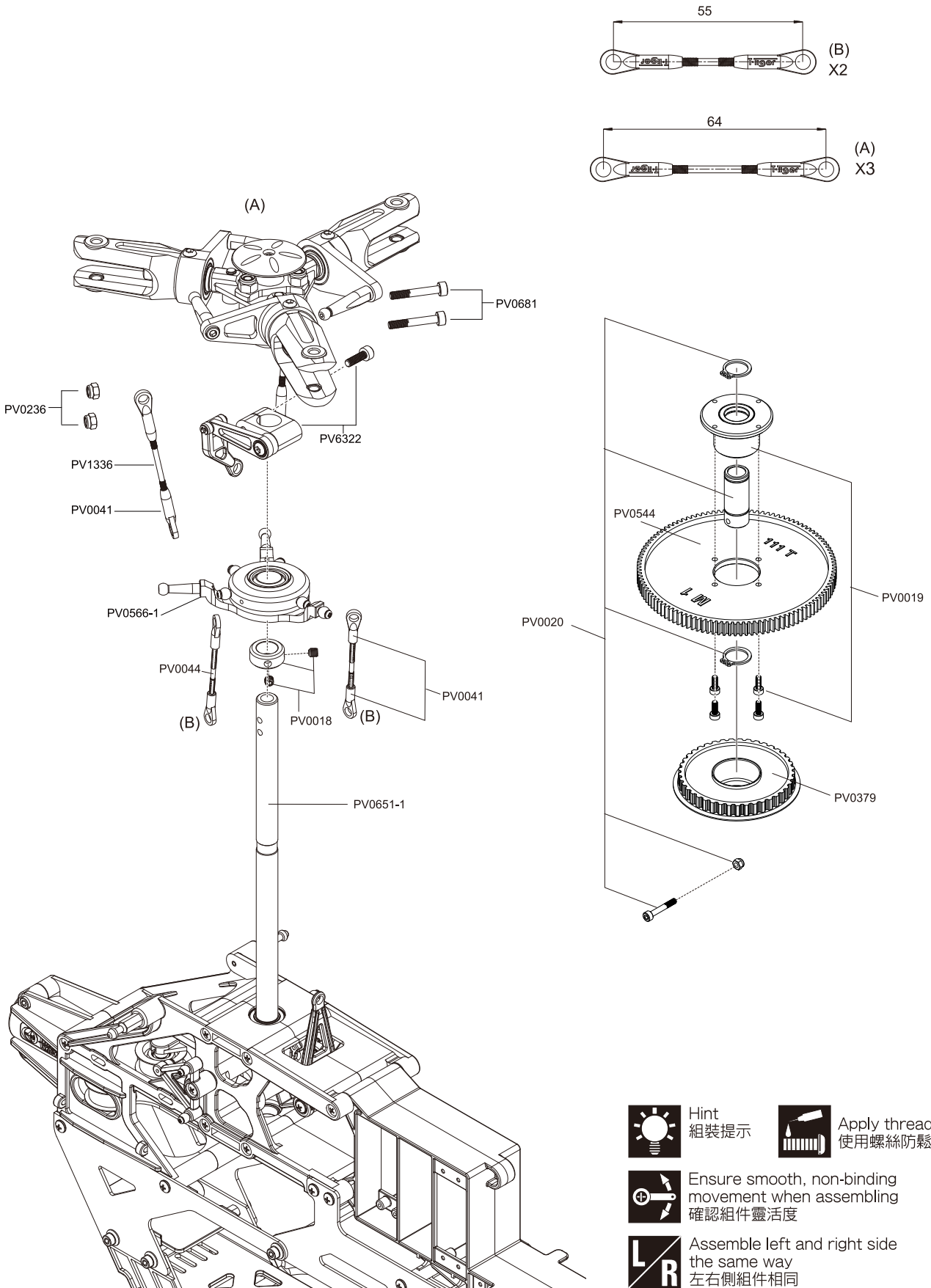

Hint  
組裝提示



Apply threadlocker  
使用螺絲防鬆膠



Ensure smooth, non-binding  
movement when assembling  
確認組件靈活度



Assemble left and right side  
the same way  
左右側組件相同

# SPARE PARTS LIST 維修零件包表格



No.	Description	中文名稱	Note
PV0018	MAIN SHAFT LOCK RING	止檔圈	SET SCREW (M4x5)X2
PV0019	ONEWAY CLUTCH	單向離合座組	SOCKET SCREW(M3*12)X4
PV0020	ONEWAY CLUTCH SHAFT	單向離合器軸	SOCKET SCREW (M3x20),NYLON NUT(M3), C-CLIP(D14)X2
PV0041	BALLLINK	單頭連接桿	
PV0044	LINKAGE ROD	連接桿組	30 mm X3 ,46 mm X3,60 mm X2 ,76 mm X2
PV0212	SOCKET SCREW,M3x10	內六角螺絲,M3X10	
PV0236	LOCK NUT,M3	止鬆螺帽,M3	
PV0379	AUTOROTATION TAIL PULLY	熄火降落旋轉尾驅動輪	SOCKET SCREW(M3*8)X4 ,
PV0544	111T MAIN GEAR	111T主齒輪組	
PV0566-1	SWASHPLATE 140°	十字盤組140度	
PV0681	MAIN HUB BOLT	主旋翼頭固定螺絲	SOCKET SCREW(M3x20)X4 ,NYLON NUT(M3)
PV0651-1	HARDENED MAIN SHAFT	強化主軸	
PV1336	LINKAGE ROD SET	連桿組	40mm X6
PV6322	RADIUS ARM BRACKET	相位器固定座	SOCKET SCREW(M3*10)*1

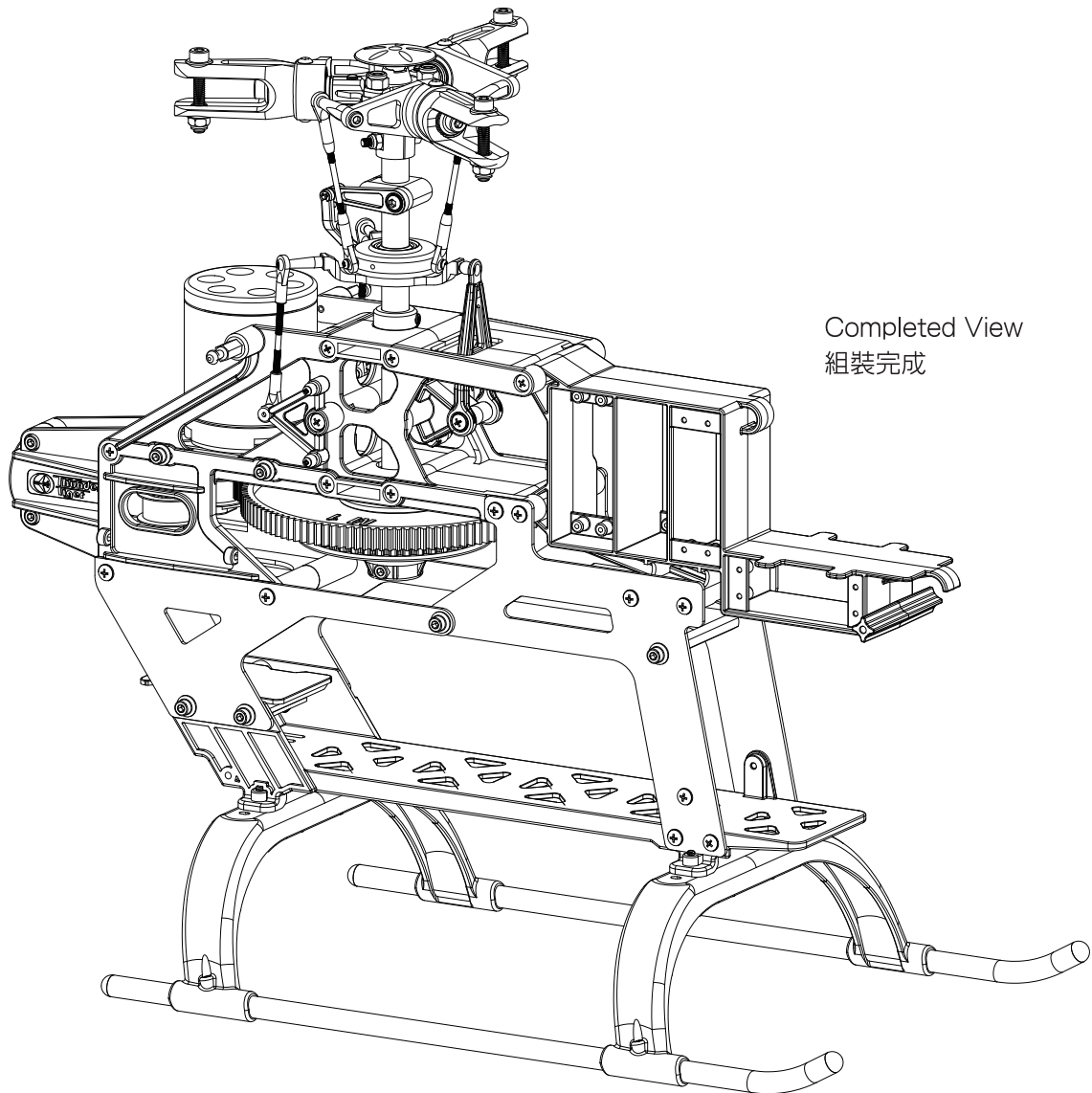

Completed View  
組裝完成

# TAIL ROTOR & TAIL UNIT 尾旋翼與尾部總成



Please note the assembling direction of the angular bearing. If they are not assembled properly as illustrated, they will easily fail and result in unexpected danger.

請注意尾部斜角滾珠軸承安裝方向。若安裝錯誤，尾部機構將失效並產生不可預期的危險。

Red Side In 紅色朝內

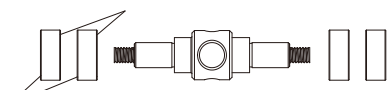

Black Side Out 黑色朝外



Add a drop of threadlocker on the thread of screws when securing into the parts which are made of metal.  
螺絲鎖固於金屬製品零件時，請酌沾適量防鬆膠。

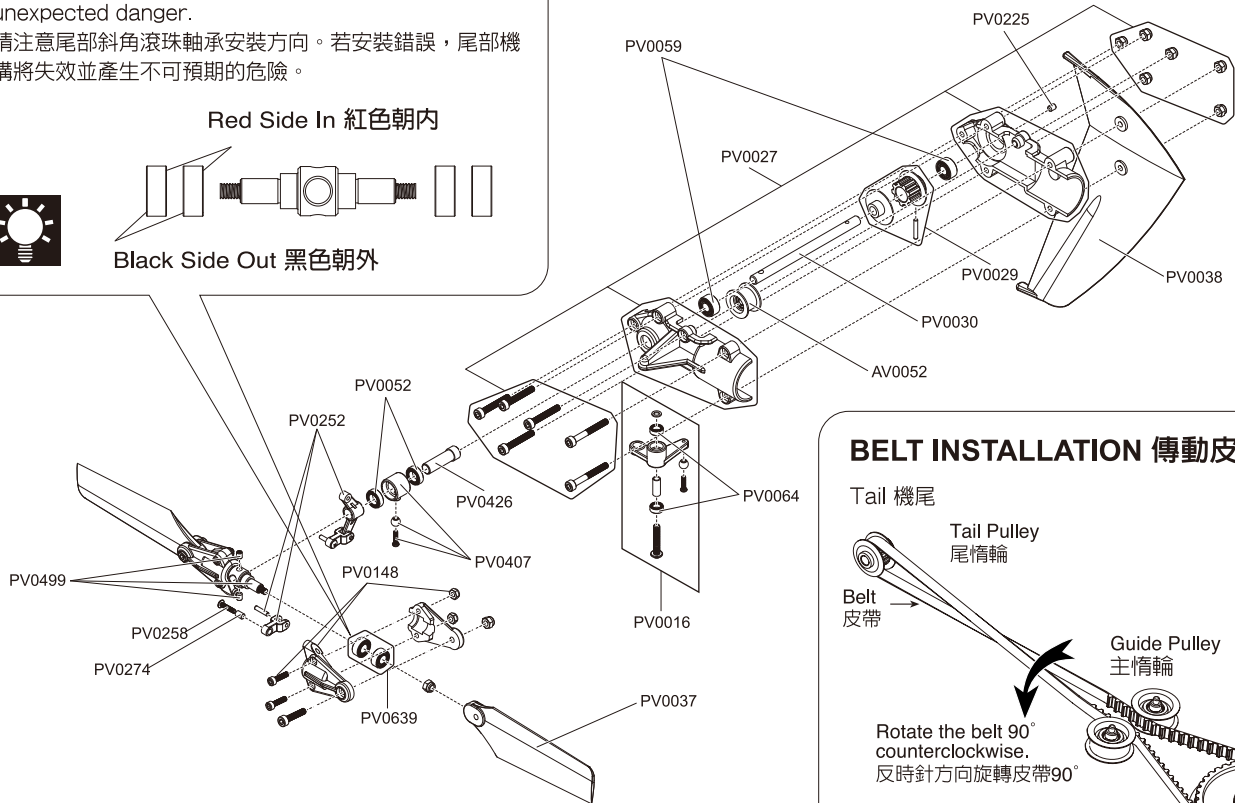

## BELT INSTALLATION 傳動皮帶安裝

Tail 機尾

Tail Pulley 尾惰輪

Belt 皮帶

Guide Pulley 主惰輪

Rotate the belt 90° counterclockwise.  
反時針方向旋轉皮帶90°

Autorotation Tail Drive Pulley 尾驅動輪

Nose 機首



Ensure smooth, non-binding movement when assembling  
確認組件靈活度

Hint  
組裝提示

Assemble left and right side the same way  
左右側組件相同

Apply threadlocker  
使用螺絲防鬆膠

# SPARE PARTS LIST 維修零件包表格



No.	Description	中文名稱	Note
AK0060	TAIL BOOM (BLACK)	尾管(黑色)	
AK0060-T	TAIL BOOM(TI)	尾管(鈦色)	
AK0089	Tail Driver belt 630XL	正時皮帶	
AV0052	TAIL IDLE PULLY	小惰輪組	
PV0016	TAIL PITCH CONTROL LEVER	尾懸翼控制桿	W/PHILLIPS MACHINE SCREW(M2*8) X 1,SELF TAPPING SCREW(M3*18) X 1,WASHER(d3*D5*W0.5) X 1,COLLAR(d3*D4*W10) X 1
PV0027	TAIL CASE	尾座組	W/ SOCKET SCREW(M3*20) X 4, SOCKET SCREW(M3*25) X 2,NYLON NUT (M3) X 6
PV0029	TAIL PULLEY SET	尾輪組	W/SET SCREW(M3*4) X 1,PIN(D2*L11.8) X 1
PV0030	TAIL ROTOR SHAFT	尾旋翼軸	W/SET SCREW(M3*4) X 1,PIN(D2*L11.8) X 1
PV0037	TAIL ROTOR BLADE	尾旋翼組	
PV0038	TAIL FIN	尾安定面組	W/SELF TAPPING SCREW(M3*12) X 2
PV0052	BALL BEARING(d6*D11*W5)	軸承組	
PV0059	BALL BEARING(d5*D11*W5)	軸承組	
PV0064	BUSHING,d4xD7xW2.5	銅襯組	
PV0148	TAIL ROTOR GRIP	尾旋翼轉座	W/ SOCKET SCREW(M2.5*10) X 4, SOCKET SCREW(M3*14) X 2,NYLON NUT(M2.5) X 4,NYLON NUT(M3) X 2
PV0225	SET SCREW,M3x4	無頭內六角螺絲,M3X4	
PV0252	TAIL CONTROL FORK	尾旋翼控制座	W/PIN(D2*L8.8) X 1
PV0258	BUTTON PHILLIPS TAPPING SCREW,M2x10	扁圓型自攻螺絲,M2x10	
PV0274	COLLAR(20),d2xD3xW4.2	軸環(10),d2xD3xW4.2	
PV0407	TAIL PITCH SLIDER	尾旋翼滑座	W/SELF TAPPING SCREW(M2*8) X 1,SELF TAPPING SCREW(M2*10) X 2,COLLAR(d2*D3*W4.2) X 2
PV0426	TAIL CONTROL BUSHING	尾旋翼控制軸套	W/SET SCREW(M3*3) X 2,NYLON NUT (M3) X 2
PV0499	SUS TAIL HUB	SUS尾旋翼固定座	W/SET SCREW(M3*3) X 2,NYLON NUT (M3) X 2
PV0550	TAIL CONTROL ROD	尾控制桿組	SET SCREW (M4x5)
PV0639	OBLIQUE BALL BEARING	斜角滾珠軸承	
PV0677	TAIL SUPPORT BRACKET	尾支撐桿固定座	W/ SOCKET SCREW(M3*16) X 2,NYLON NUT (M3) X 2
PV0679	TAIL SUPPORT (AL)	尾管支撐架組(鋁色)	W/SELF TAPPING SCREW(M2*8) X 4
PV0679-T	TAIL SUPPORT (TI)	尾管支撐架組(鈦色)	W/SELF TAPPING SCREW(M2*8) X 4
PV1377	ROD GUIDE	固定環	W/TAPPING SCREW(M2*6) X 3
PV1423	TAIL SUPPORT BRACE	尾管支撐架連接座	W/ SOCKET SCREW(M3*10) X 1,NYLON NUT (M3) X 1
*PV0675	METAL TAIL PULLEY	金屬尾輪組	OPTIONAL PARTS

\* Indicating the parts are optional parts and not come with this product.

\* 該零件為改裝品且不包含於本產品中

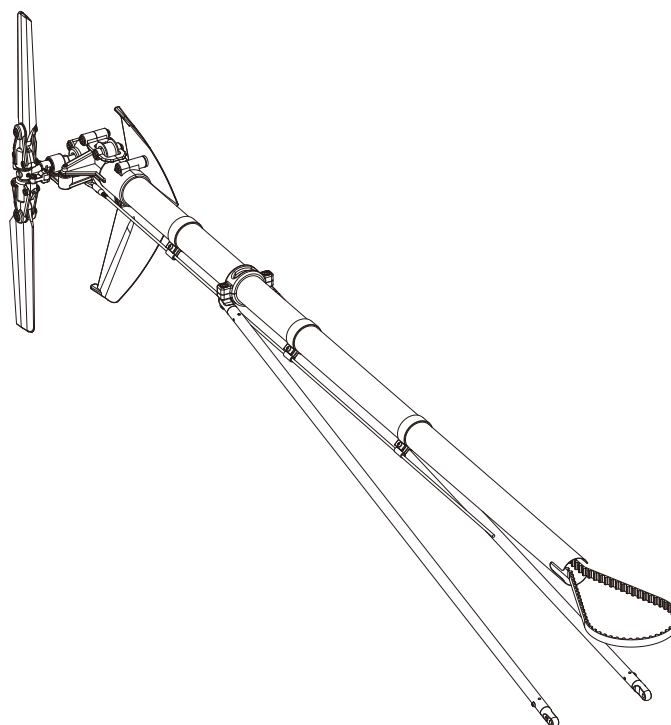

Completed View  
組裝完成

# SERVO WITH LINKAGE ROD 伺服機連桿



The distance from the center of the servo horn to both sides of the linkage balls should be the same.  
 伺服機擺臂中心至兩邊球頭距離必需相等。

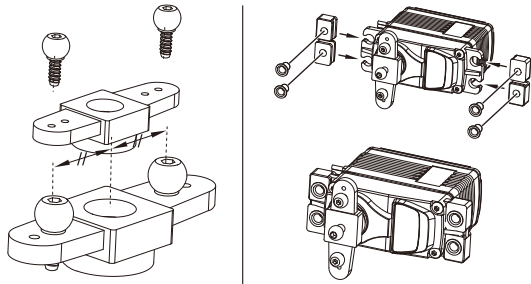

Add a drop of threadlocker on the thread of screws when securing into the parts which are made of metal.  
 螺絲鎖固於金屬製品零件時，請酌沾適量防鬆膠。

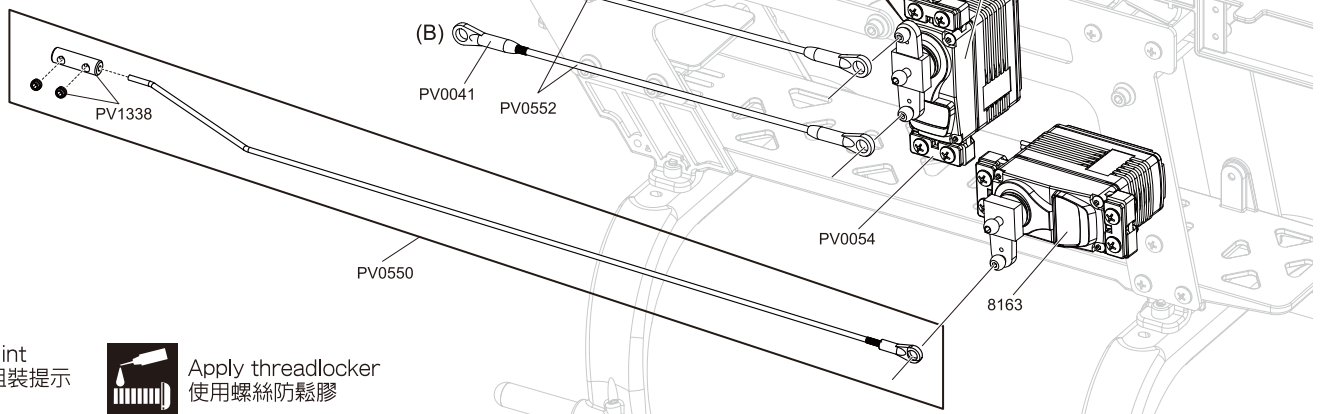
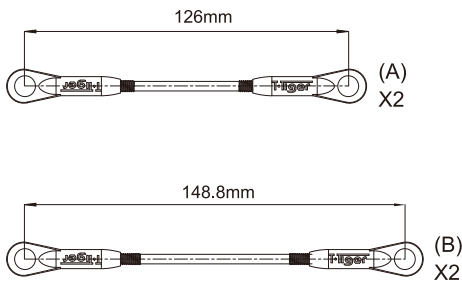

Hint  
組裝提示



Apply threadlocker  
使用螺絲防鬆膠



# SPARE PARTS LIST 維修零件包表格



No.	Description	中文名稱	Note
8179	HIGH-TORQUE SERVO,DS1510MG	伺服機,DS1510MG	
8163	DIGITAL TAIL SERVO(NARROW) ,DS0606n	窄頻數位伺服機,DS0606n	
PV0041	BALLLINK	單頭連接桿	
PV0054	SERVO MOUNTING PLATE	伺服機固定片組	
PV0058	LINKBALL	連接頭	
PV0088	SCREW BAG	圓頭十字螺絲組	
PV0550	TAIL CONTROL ROD	尾控制桿組	SET SCREW (M4x3)
PV0552	LINKAGE ROD	連接拉桿組	30mmX2 , 46mmX2 ,76mmX2 ,107mmX2 ,130mmX2
PV1338	TAIL CONTROL ROD JOINT	尾控制桿軸環	SET SCREW (M4x3)

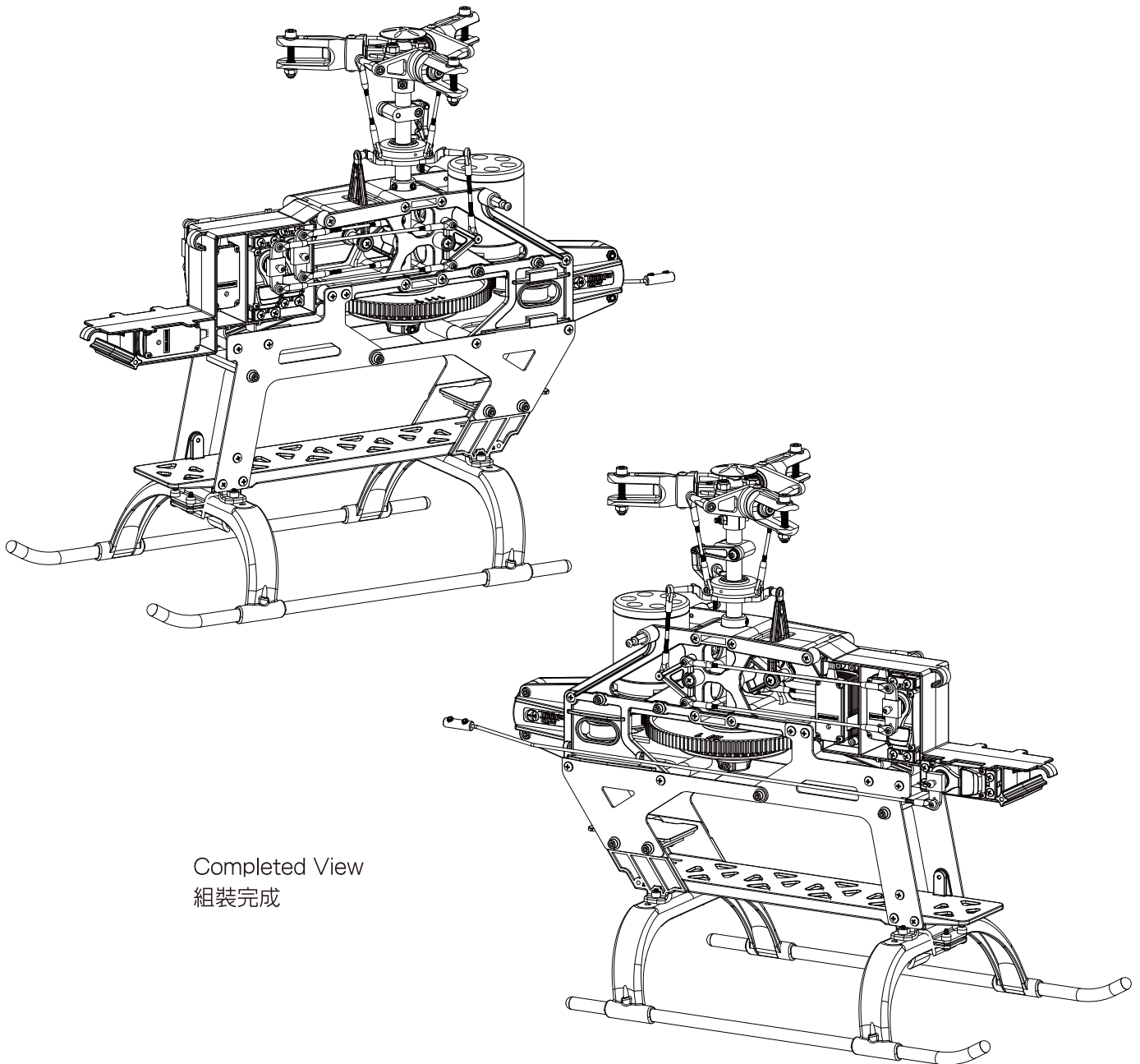

Completed View  
組裝完成

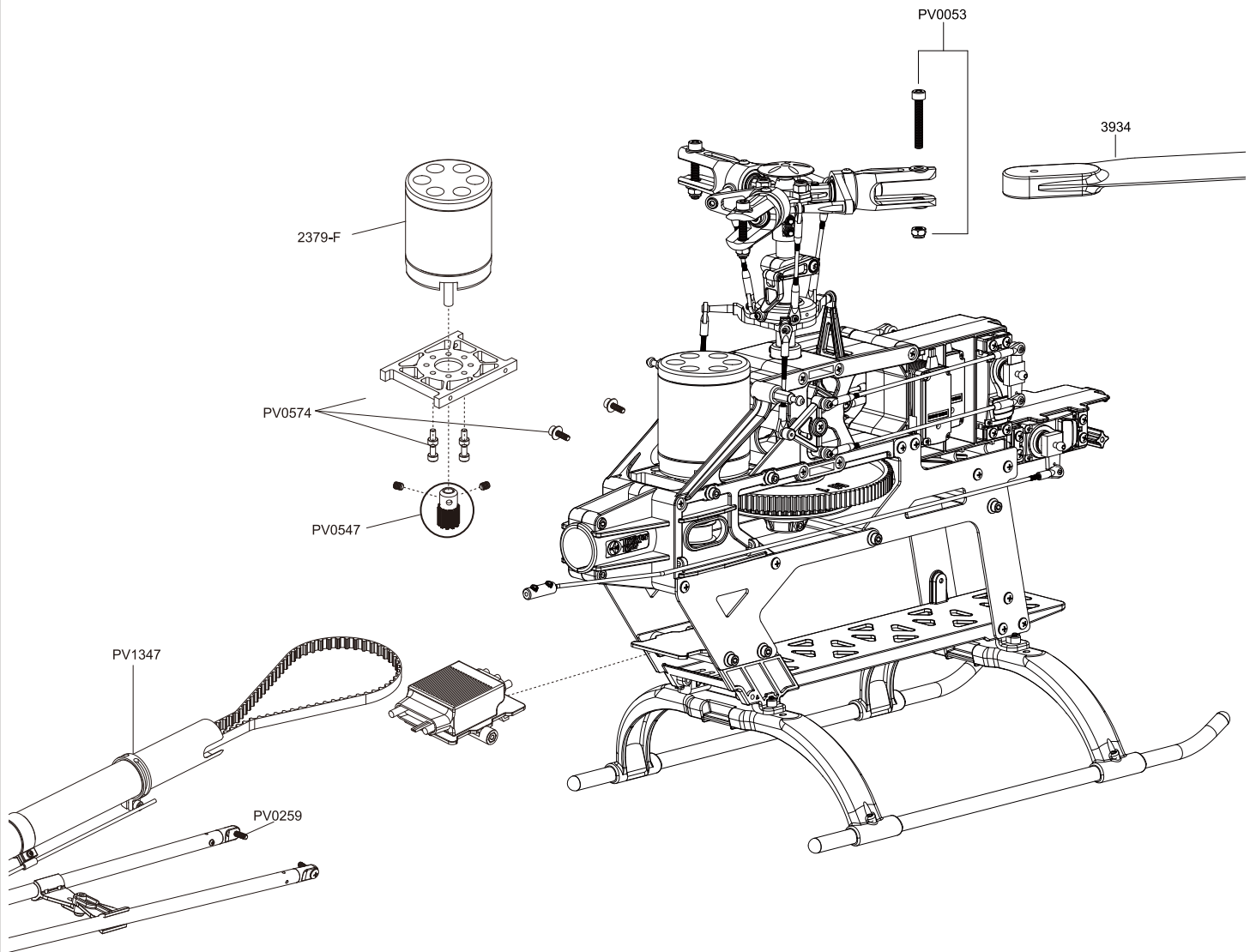
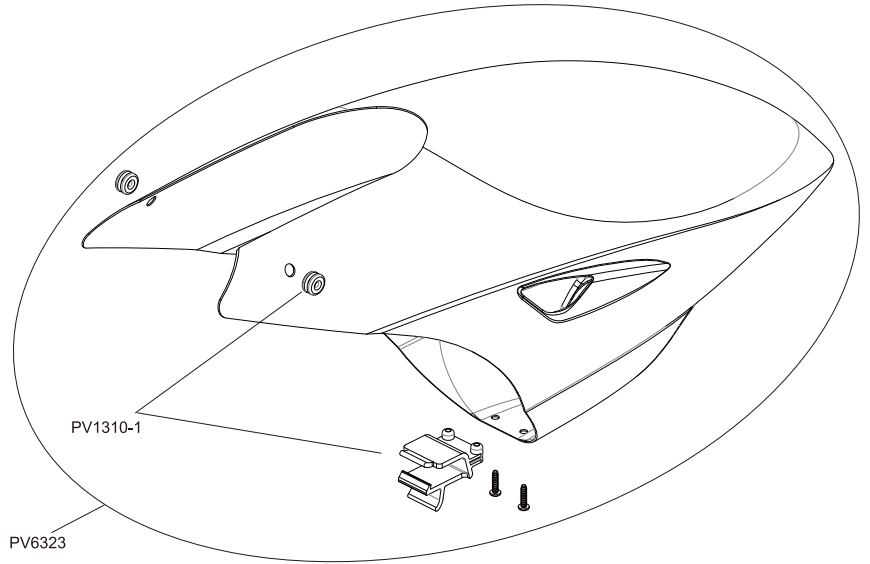
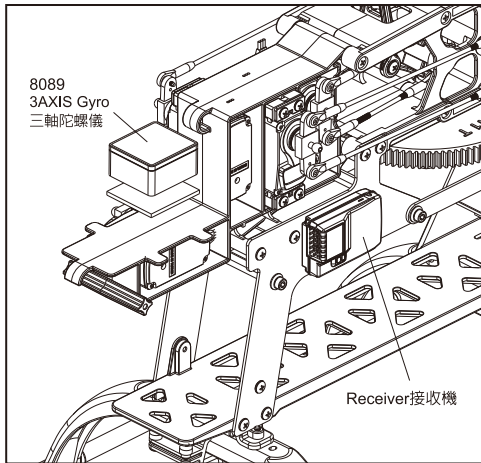

# SPARE PARTS LIST 維修零件包表格



No.	Description	中文名稱	Note
8089	GT5.2 GYRO	三軸陀螺儀	3AXIS GYRO
PV0053	ROTOR BOLT	主旋翼螺絲組	SOCKET SCREW (M4x27)X2 ,NYLON NUT(M4)X2
PV0259	BUTTON PHILLIPS TAP SCREW,M3x12	扁圓型自攻螺絲,M3x12	
PV0384	WIRE CLAMP	電線整理座零件包	
PV0547	MOTOR PINION 11T	驅動齒輪組 11T	
PV0574	MOTOR MOUNT	馬達固定座	SOCKET SCREW (M3x10)X4 ,(M3*6)X4 ,WASHER (d3xD8xW1.4)X4
PV1310-1	CANOPY BRACKET	機殼固定座	SELF TAPPING SCREW(M3*12)X2
PV1347	TAIL BOOM CLAMP	尾管止檔環	SOCKET SCREW (M3x10)
PV6314-R	DECAL (RED/GOLDEN)	貼紙 (紅/金)	
PV6314-C	DECAL (CYAN/BLUE)	貼紙 (青/藍)	
PV6323	ABS CANOPY	ABS機殼	SELF TAPPING SCREW(M3*12)X2
*PV0545	MOTOR PINION 9T	驅動齒輪組 9T	OPTION PARTS
*PV0546	MOTOR PINION 10T	驅動齒輪組 10T	OPTION PARTS
*PV0548	MOTOR PINION 12T	驅動齒輪組 12T	OPTION PARTS
*PV0549	MOTOR PINION 13T	驅動齒輪組 13T	OPTION PARTS
*PV0269	PLASTIC GEAR GREASE	塑膠軸承潤滑脂(白色)	OPTION PARTS
*PV0517	ONEWAY GREASE	單向軸承潤滑脂(白色)	OPTION PARTS
*PV0270	THRUST BEARING GREASE	止推軸承潤滑脂(黑色)	OPTION PARTS
*3892	CFK TAIL BLADE 95MM	95MM碳纖維尾旋翼	OPTION PARTS
*PV0678-1	CARBON VERTICAL FIN	碳纖垂尾	OPTION PARTS
*PV0457	METAL TAIL PITCH SLIDER	金屬尾旋翼控制滑座	OPTION PARTS
*PV1413	TAIL CONTROL ROD JOINT ( BLACK )	尾控制桿軸環(黑色)	OPTION PARTS
*PV0512-W	SKID DAMPER(W),R30/50	腳架墊圈(白)	OPTION PARTS
3934	CARBON 3-BLADE, 550MM	碳纖主旋翼(三槳)550MM	

\* Indicating the parts are optional parts and not come with this product.

\* 該零件為改裝品且不包含於本產品中

